

# User Manual

**ATM-PVS-50**

Date: August 2024

Version: 1.2

## About This Manual

- This manual introduces the operation of user interfaces and menu functions of **AMT-PVS-50**.
- The pictures in this manual may not be exactly consistent with those of your product; the actual product's display shall prevail.
- Not all the devices have the function with ★, which the real product prevails.

# Table of Contents

- 1 PRODUCT INTRODUCTION ..... 1
  - 1.1 OVERVIEW ..... 1
  - 1.2 PRODUCT FEATURES ..... 1
- 2 PRODUCT SPECIFICATIONS ..... 3
  - 2.1 TECHNICAL SPECIFICATIONS ..... 3
  - 2.2 OPTICAL AND IMAGE SPECIFICATIONS..... 3
- 3 ALGORITHM PARAMETERS ..... 4
  - 3.1 PALM RECOGNITION ALGORITHM ..... 4
    - 3.1.1 PALM RECOGNITION PARAMETERS ..... 4
    - 3.1.2 REQUIREMENTS FOR PALM REGISTRATION IMAGE QUALITY ..... 4
- 4 APPLICATION SCENARIOS ..... 6
- 5 STRUCTURE DIMENSION ..... 9
- 6 INTERFACE DEFINITIONS ..... 10
  - 6.1 INTERFACE LOCATION AND DEFINITION ..... 10
  - 6.2 INTERFACE SOCKET SIZE ..... 10
- 7 WIRE REQUIREMENTS ..... 11
- 8 DESIGN GUIDANCE ..... 12
  - 8.1 COOLING RECOMMENDATIONS ..... 12
  - 8.2 ELECTRONIC DESIGN ..... 12
    - 8.2.1 POWER AND CONSUMPTION ..... 12
    - 8.2.2 MODULE ESD PROTECTION ..... 13
  - 8.3 ENVIRONMENT AND RELIABILITY..... 13
- 9 INSTALLATION INSTRUCTION ..... 14
  - 9.1 INSTALLATION MODE..... 14
- APPENDIX ..... 15
  - SUPPLIER'S DECLARATION OF CONFORMITY COMPLIANCE INFORMATION ..... 15
  - FCC INFORMATION (FOR US CUSTOMERS)..... 16
  - EU DECLARATION OF CONFORMITY ..... 17
  - WEEE NOTICE ..... 17
  - ACCESSORIES INCLUDED ..... 18

# 1 Product Introduction

## 1.1 Overview

The AMT-PVS-50 is a standalone dual-camera palm module, expertly designed with high-performance heterogeneous processor architecture. This innovative module seamlessly integrates multiple palm recognition functionalities into one unit including image acquisition, quality evaluation, image transmission, palm liveness detection, template extraction, matching, and management operations. It stands out for its lightweight, compact size, excellent adaptability to varying lighting conditions, contactless authentication operation, and its ability to recognize both palmprints and palm veins.

The module's design is based on a dual-camera imaging architecture, combined with a high-performance Image Signal Processor (ISP). It excels in both dark night (as low as 0.01 Lux) and direct sunshine (up to 100000 Lux) outdoor environments, ensuring the capture of high quality palm images. A built-in AI module enhances its capabilities, enabling accurate palm detection with the assistant of Auto Exposure on Region of Interest (AE on ROI) feature, resulting in the production of high-quality true-color and infrared-light palm print and palm vein images. Furthermore, this AI module is equipped with an advanced palm liveness algorithm, allowing for highly secured anti-spoofing protection.

The dual-camera palm module is versatile, thanks to its built-in algorithm and flexible architecture, making it well-suited for a variety of scenarios. It offers three distinct application modes to cater to different deployment scenarios. These deployment modes include:

- Capturing palm video streams and transmitting to the 3rd party system with UVC protocol serving as a biometric collection module;
- Capturing palm video streams and extracting palm features within the module, and completing palm matching on the host device;
- Capturing palm video streams, extracting palm features and completing palm matching on the module.

The choice of deployment method can be tailored to suit specific business requirements and platform configurations, leveraging the full potential of the dual-camera palm module. The module is provided with rich interfaces for software integration development, facilitating rapid integration of palm recognition capabilities into various application platforms, suitable for time attendance, access control, entrance management, identity authentication, and many other application fields where personal identity authentication is required in an efficient and secured way.

## 1.2 Product Features

- Dual-core Cortex-A53 up to 800MHz, offering computing power up to 1.5TOPs.
- Palm recognition distance: 5cm - 15cm.
- The palm recognition algorithm is adaptable to varying lighting conditions ranging from 0.01Lux to 100,000Lux.

- Supports Auto Exposure on Region of Interest (AE on ROI), ensuring high quality palm image captured in low, strong or adversary lighting conditions.
- Supports pixel-to-pixel level alignment between captured RGB image and infrared-light image.
- Supports low-latency time synchronization between captured RGB image and infrared-light image.
- The palm recognition algorithm supports palm detection, liveness detection, template extraction and palm matching operations.
- Provides feature-rich and full-function SDK, supporting mainstream platforms: Windows, Android, and Linux (on request).
- Supports UVC protocol for image transmission and HID protocol for data transmission of palm template and matching results.
- The software architecture is flexible and open for deployment, suitable for various application integration scenarios.
- Integrated USB interface for both data communication and power supply.

## 2 Product Specifications

### 2.1 Technical Specifications

Name	Specification
Processor	800MHZ Dual Core Cortex A53 Processor, 1.5 TOPs NPU
Image Sensor	Dual 1/5' Global shutter CMOS with 1.3MP
Memory	256MB RAM and 256MB Flash
Comm Interface	USB 2.0
Comm Protocol	UVC + HID
Power Supply	DC 5V/2A
Power Consumption	< 2W (standby); < 3W (operation)
Dimension	62mm*62mm*20mm (Length*Width*Height)
Supported OS	Android 7, 8, 9, 10; Windows 7, 10, 11; Linux (on request)

### 2.2 Optical and Image Specifications

Type	Visible Palm Print	Infrared Palm Vein
Native Resolution @ Frame Rate	1024*1280@30fps	
Output Resolution @ Frame Rate	720*1280@30fps	
Pixel Size	2.2um	
Shutter Type	Global Shutter	
Focus	Fixed Focus	
Default Output Format	MJPEG	
Minimum Illuminance	0.01 Lux	
Maximum Illuminance	100,000 Lux	
Image Distortion Rate	≤2%	
FOV (Field of View)	Horizontal: 116°, Vertical 95°, Diagonal: 145°	
Auto Exposure	Support Palm AE	
Image Time Alignment	Maximum delay between frames: 10ms	
Image Spatial Alignment	±5 pixel	
Supplementary Light Wavelength	440 nm to 650 nm	850nm
Filter (or Light Filter)	Infrared cut-off filter	Infrared band-pass filter

### 3 Algorithm Parameters

#### 3.1 Palm Recognition Algorithm

The palm recognition technology integrates multimodal recognition of palm prints and palm veins, designed for varying lighting environments, wide posture tolerance, and large-capacity recognition needs. This highly effective multimodal palm recognition algorithm significantly enhances the robustness and pass rate of palm recognition by focusing on wide adaptability to deployed environments and friendly user experience while ensuring an extremely low false acceptance rate.

##### 3.1.1 Palm Recognition Parameters

Algorithm Version	Palm
Recognition Distance	5cm-15cm
Recognition Mode	1:1, 1:N
1:N Capacity	30,000
Liveness Detection	Infrared-visible light mode; Infrared light mode
Palm Liveness Detection Time	<20ms
Feature Template Extraction Time	<25ms
Comparison Time	<30ms
Posture Adaptability	Yaw ≤ 30°, Pitch ≤ 45°, Roll ≤ 180°, Bend ≤ 20°
Accuracy	FRR = 0.17% when FAR = 0.001%

##### 3.1.2 Requirements for Palm Registration Image Quality

Palm images for image-based enrollment must be in JPG or BMP format, with a resolution of not less than 480\*640 Pixels. The images should clearly separate the palm from the background and prominently show the palm vein patterns. The palm should be complete and in its entirety with the correct proportions on the image taken under even lighting. The pitch angle, yaw angle, roll angle, and bending should not exceed ±5 degrees. The adjusted palm images should include every joint from the palm base to each finger, as illustrated in Fig 3-1.

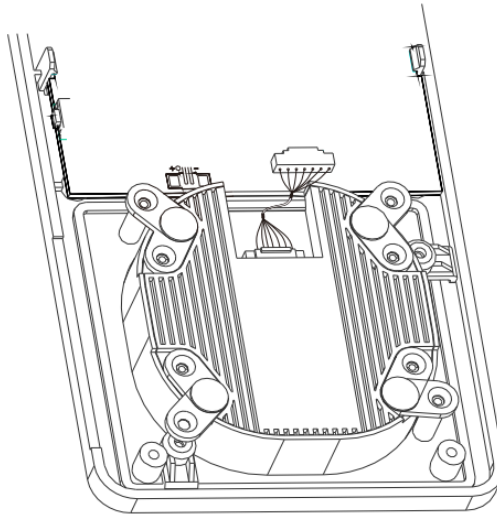

Figure 3-1 Palm Image for Registration



## 4 Application Scenarios

The AMT-PVS-50 dual-camera palm module is designed for easy and quick integration with hosting devices, thanks to its built-in design philosophy and optimal structural treatment. Its highly integrated design allows for power and communication connection to hosting platform through a single USB cable, significantly simplifying development efforts for clients. The following is an application integration example, highlighting the module's adaptability and ease of installation on various application platforms.



**Figure 4-1 Schematic Diagram of Dual-Camera Palm Module Integrated Application**

To enhance the adaptability of the dual-camera palm module to various platforms and to minimize the development cost and workload for the clients, the module integrates all functions within the biometric identification application process. These functions include image capture, image transmission, template extraction, template comparison, template management, and output of comparison results. All functions can be configured via application software, allowing clients to fast develop the application using the SDK to achieve the desired functionalities and complete the product application design.

### *Image Capture and Transmission:*

Palm image capture and transmission operations are performed inside the module. The transmission can be configured at different resolution level as per client requirements. Please refer to the "Optical and Image Parameters Table" of the supported resolutions and frame rates. The image transmission takes the UVC standard protocol where the RGB and near-infrared images are transmitted through their respective UVC port, allowing clients to choose the port as needed.

### *Template Comparison and Management:*

Palm template comparison and management can be configured to be operated either on the palm module unit or on the hosting device, depending on the customer business requirement and target. The module offers three application modes for different scenarios, including:

- **Image Capturing Mode:** Transmit the capture palm images to the hosting platform over UVC protocol-based video stream, palm template extraction and comparison are performed on the hosting platform.

- Matching on Module Mode: Perform palm image capture, liveness detection, template extraction, and comparison inside the module unit.
- Matching on Host Mode: Capture the palm image internally, perform palm template extraction operation inside the module, transmit the template to the hosting platform where to perform palm template matching operation.

When Matching-on-Host mode is picked to perform palm template comparison and data management, the palm template which is extracted/created on the palm module shall be pushed to the hosting platform via HID port for recognition and storage processing. This approach is applicable to scenarios where the factors such as larger capacity, higher security, developer experience and performance are considered. A functional diagram of the matching-on-host system is illustrated in Figure 4-2.

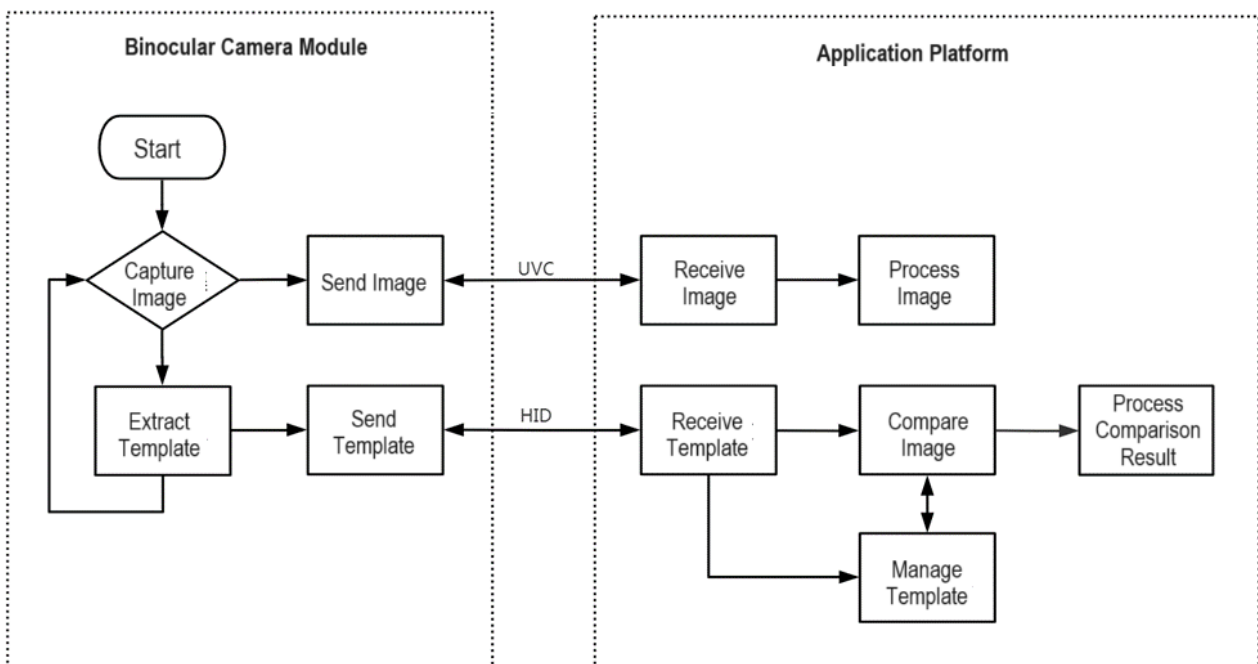

Figure 4-2 Functional Diagram of The Matching-on-Host System

When Matching-on-Module mode is picked to perform template comparison and data management directly on the module, the module outputs the comparison result through the HID port to the host application for further business process after the comparison is completed. This approach minimizes computing resource consumption on the host application platform, making it suitable for integrating palm recognition functions on low-performance embedded host device. A functional diagram of the Matching-on-Module system is illustrated in Figure 4-3.

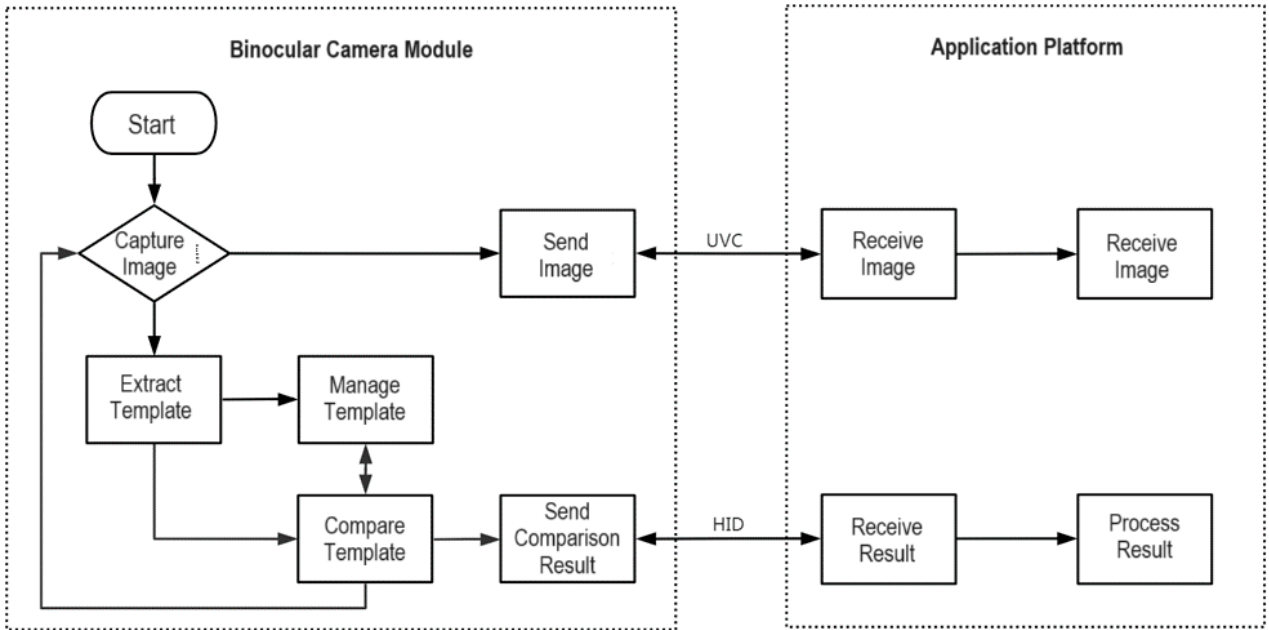

Figure 4-3 Functional Diagram of The Matching-on-Module System

With help of the full-and-rich-featured SDK, customers can build and integrate the palm recognition features into their business application by simply calling and configuring the corresponding functional interfaces of the SDK, which significantly shortens the development cycle, fasts the product delivery and boosts the product competitiveness in the market.

## 5 Structure Dimension

The overall structural dimensions of the dual-camera palm module are shown in Figure 5-1.

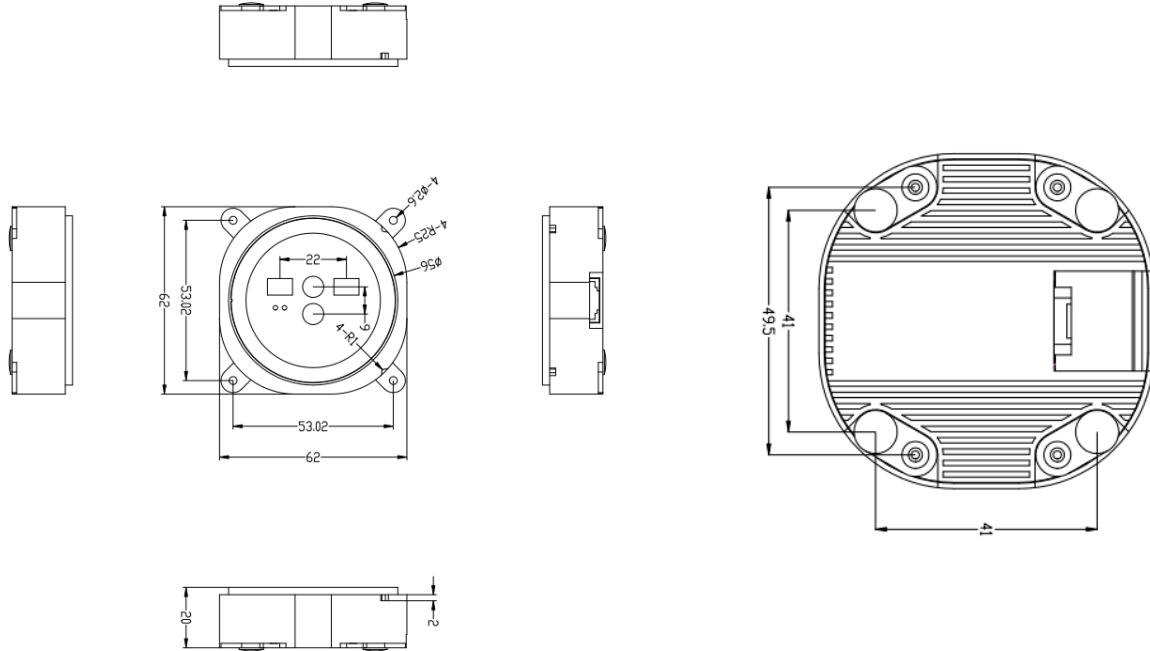

Figure 5-1 Structural Dimensions of Dual-Camera Palm Module

## 6 Interface Definitions

### 6.1 Interface Location and Definition

The interface of the dual-camera palm module is a 1.25mm-9Pin snap-in socket, and its location and pin definition is presented in Figure 6-1 below:

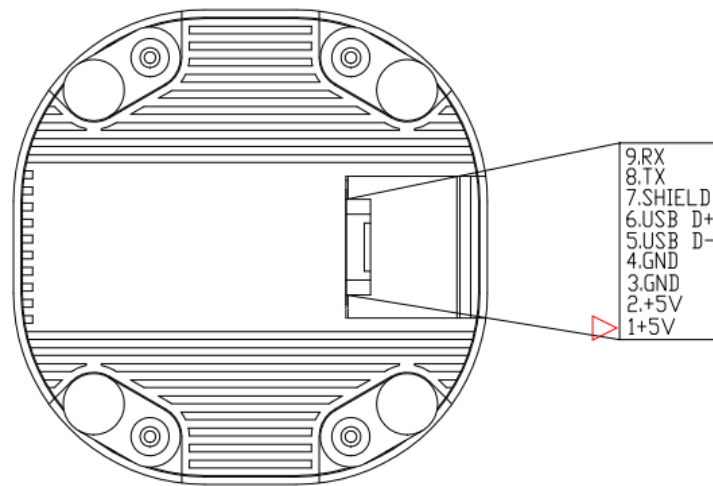

Figure 6-1 Palm Module Interface Definition

### 6.2 Interface Socket Size

The interface of the dual-camera palm module is a 1.25mm-9Pin female socket with buckle, and the specific dimensions are shown in Figure 6-2:

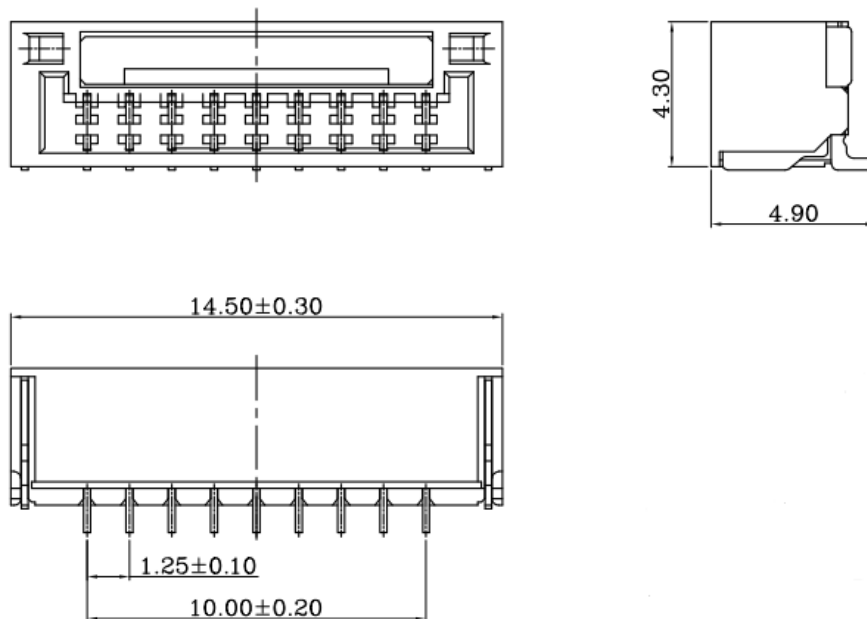

Figure 6-2 Dimensional Diagram of 5-Pin Interface Receptacle

## 7 Wire Requirements

For optimal USB signal transmission, it's recommended to use 26AWG twisted pair cables for D+/D- signals. The total length of the cable with dual plugs should not exceed 15cm. To enhance the USB cable anti-interference capability, it should have a shielding layer with a braiding density of 64 or higher. A reference design illustrates the cable specification, ensuring reliable communication and power supply for devices.

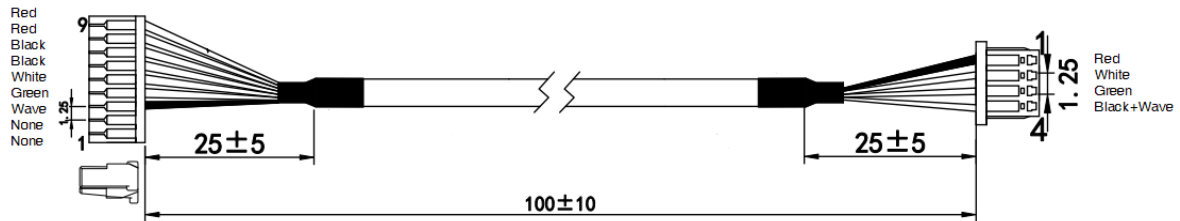

Figure 7-1 Schematic Diagram of Double-Plug Cable Specifications

# 8 Design Guidance

## 8.1 Cooling Recommendations

1. For enhancing thermal conduction at the bottom of the module, a thermal conductive silicone pad can be used. The pad should be compression resistance with low rebound force and have a thermal conductivity of  $\geq 3\text{w/m.k}$ . It is recommended that the pad's thickness be less than 2mm. The attachment placement can refer to the blue area depicted in the diagram, ideally covering the entire back of the module.
2. The heat from the thermal silicone pad should be conducted to a metal heatsink. The material of the heatsink can be aluminum alloy CNC or die-cast aluminum alloy, with a thermal conductivity of  $\geq 90\text{w/m.k}$ . For optimal cooling, exposing part of the heatsink to the exterior of the machine for air contact and convection can enhance the cooling effect.

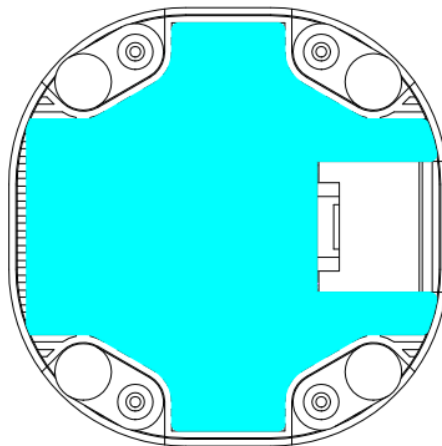

Figure 8-1 Schematic Diagram of Module Heat Dissipation

## 8.2 Electronic Design

Please make sure to keep the device's antenna as far away from the USB palm module as possible.

### 8.2.1 Power and Consumption

It's advised to design the AP motherboard to supply power to the USB palm module up to 5V/2A, to ensure compatibility and product lifecycle stability.

A table of power consumption is as follows:

Operating Conditions	Power Consumption W	Voltage V	Average Current A	Peak Current A
Standby Mode	2.0	5.0	0.4	
Operation Mode	2.7	5.0	0.54	<1A

**Notes:**

- The motherboard of host device must ensure that the voltage range supplied to the Palm Module input port is 4.75~6V.
- The above power consumption data from the product sample is for design reference.

**8.2.2 Module ESD Protection**

When there is no cable connection between the main board and the palm module, the metal enclosure of the palm module conducts with the GND of the host device, and the impedance is <math>2\Omega</math>.

**8.3 Environment and Reliability**

Item		Specs
Operation Environment	Temperature	-10°C to 55°C
	Humidity	Relative Humidity: 0% to 95%, non-condensing
	Illumination	0.01 to 100000Lux
Storage Environment	Temperature	-40°C to 85°C
	Humidity	Relative humidity: 10% to 95%, non-condensing
ESD Rating		Contact discharge ±4KV, Air discharge ±8KV
RE Rating		Comply with GB 9254 CLASS B specification
Operating Life		3+ Years
Certifications		CE, FCC, RoHS, WHQL



# 9 Installation Instruction

## 9.1 Installation Mode

The dual-camera palm module is based on its built-in design considerations, it is recommended to use rear-locking or front-locking mounting and fixing method. The explanation of rear-locking type and its mounting and fixing method is shown in Figure 9-1 as follows.

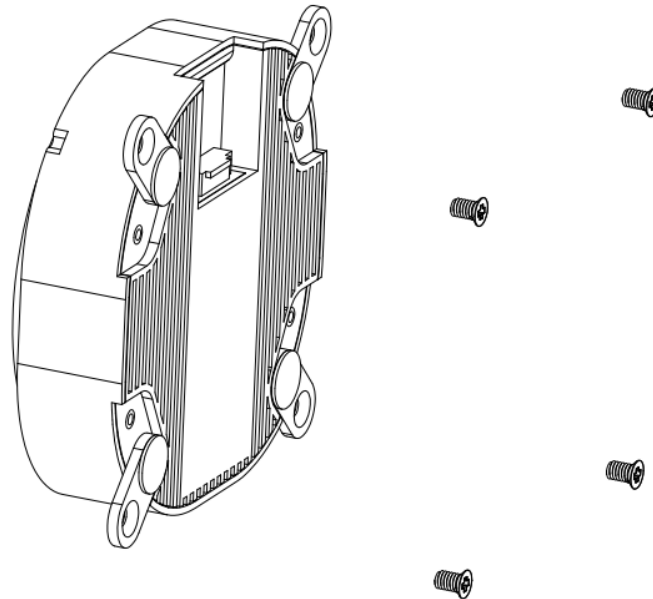

Figure 9-1 Dual-Camera Palm Module Rear Locking Mounting Diagram

# APPENDIX

## Supplier's Declaration of Conformity Compliance Information

Unique Identifier	
Product Description	High Precision Dual Camera Standalone Palm Module
Model Number	AMT-PVS-50
Trade Name	Armatura
FCC Compliance Statement	
This device complies with part 15 of the FCC Rules. Operation is subject to the following two conditions: (1) This device may not cause harmful interference, and (2) this device must accept any interference received, including interference that may cause undesired operation.	
Responsible Party – U.S. Contact Information	
Company:	Armatura LLC
Address:	190 Bluegrass Valley Parkway Alpharetta, GA 30005, USA
Telephone or internet contact information:	sales@armatura.us

## FCC INFORMATION (for US Customers)

### Warning:

Any changes or modifications to this unit not expressly approved by the party responsible for compliance could void the user's authority to operate the equipment.

### NOTE:

This equipment has been tested and found to comply with the limits for a Class B digital device, pursuant to part 15 of the FCC Rules. These limits are designed to provide reasonable protection against harmful interference in a residential installation. This equipment generates, uses and can radiate radio frequency energy and, if not installed and used in accordance with the instructions, may cause harmful interference to radio communications. However, there is no guarantee that interference will not occur in a particular installation. If this equipment does cause harmful interference to radio or television reception, which can be determined by turning the equipment off and on, the user is encouraged to try to correct the interference by one or more of the following measures:

- Reorient or relocate the receiving antenna.
- Increase the separation between the equipment and receiver.
- Connect the equipment into an outlet on a circuit different from that to which the receiver is connected.
- Consult the dealer or an experienced radio/TV technician for help.

## EU Declaration of Conformity

Hereby, Armatura LLC declares that the radio equipment type AMT-PVS-50 is in compliance with Directive 2014/53/EU.

The full text of the EU declaration of conformity is available at the following internet address:

<http://armatura.us>.

Armatura LLC

190 Bluegrass Valley Parkway, Alpharetta, GA, 30005, USA



## WEEE Notice



Correctly dispose of this product. This marking indicates that this product should not be disposed with other household wastes throughout the EU. To prevent possible harm to the environment or human health from uncontrolled waste disposal, recycle responsibly to promote the sustainable reuse of material resources. To safely recycle your device, please use return and collection systems or contact the retailer where the device was originally purchased.

For more information, contact us at the following contact information.

Armatura LLC

190 Bluegrass Valley Parkway, Alpharetta, GA, 30005, USA

## Accessories Included

- 5V/2A AC/DC Power Adapter, x1.

# ARMATURA

---

ARMATURA LLC    [www.armatura.us](http://www.armatura.us)    E-mail:[sales@armatura.us](mailto:sales@armatura.us)  
Copyright © 2024 ARMATURA LLC. All rights reserved.