

# Nergal-S4000 & Nergal-S4200

## Installation Guide

Version: 1.0

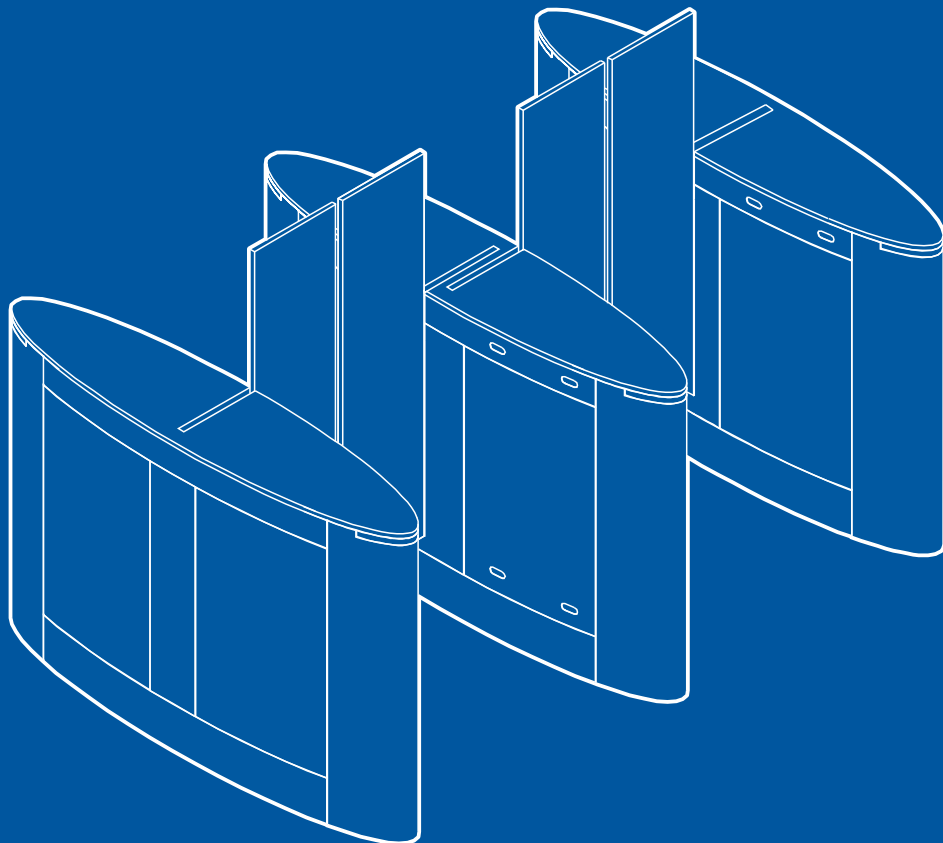

## ***Revision History***

<b>Revision</b>	<b>Date</b>	<b>Author</b>	<b>Reviewer</b>	<b>Description</b>
V1.0	09/20/2024	Julia.Huang		Original Document
V1.0	03/17/2025	Julia.Huang		Change the product model to Nergal-S4000 / Nergal-S4200.

# 1 Overview

## Nergal-S4000

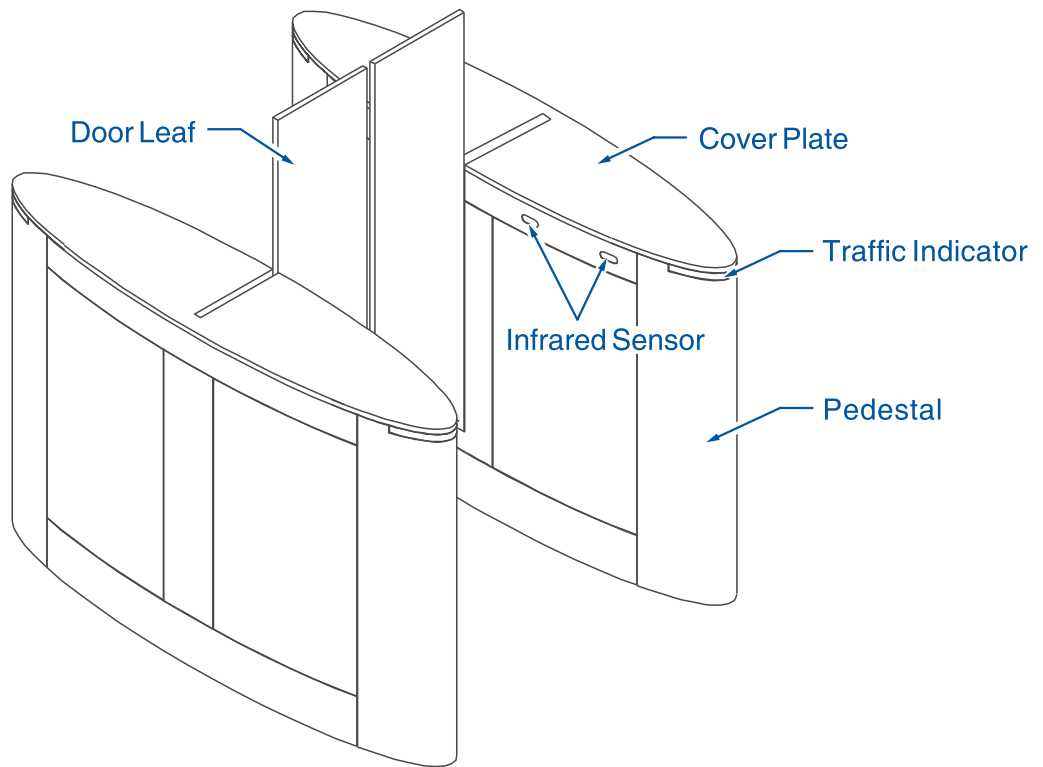

## Nergal-S4200

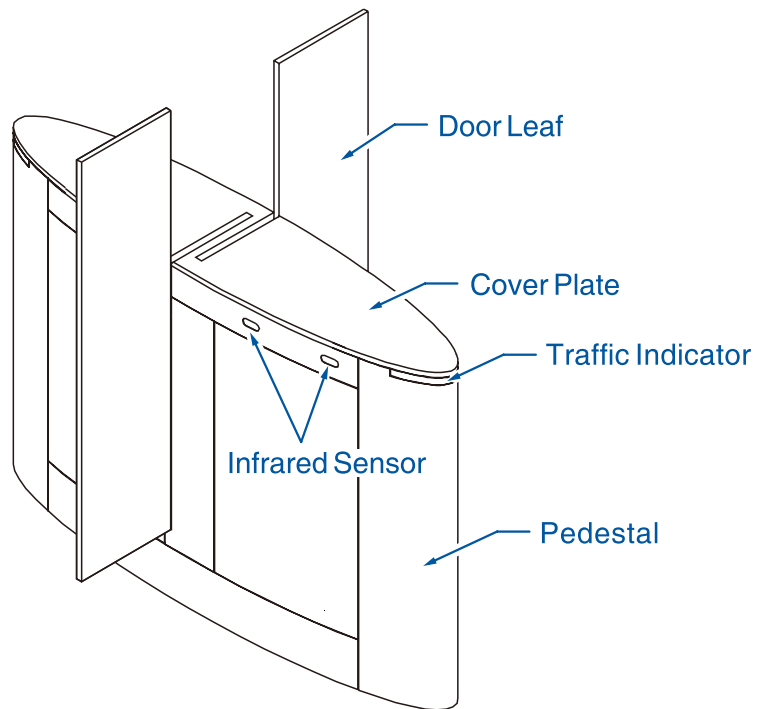

# 2 Dimensions

## Nergal-S4000

Unit: inch/mm

Bottom View

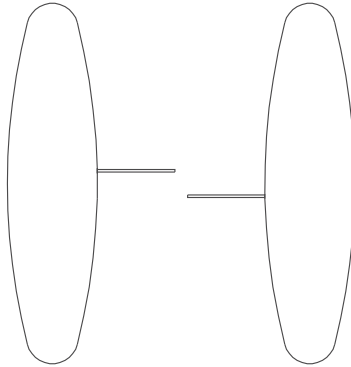

Side View

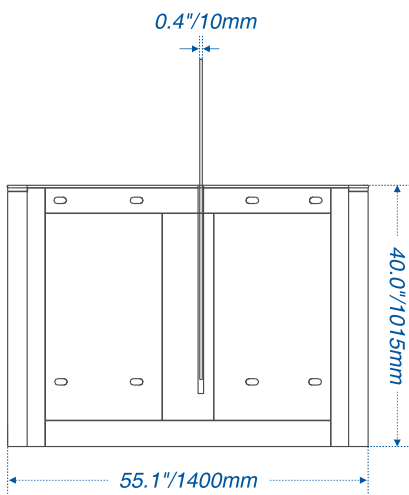

Front View

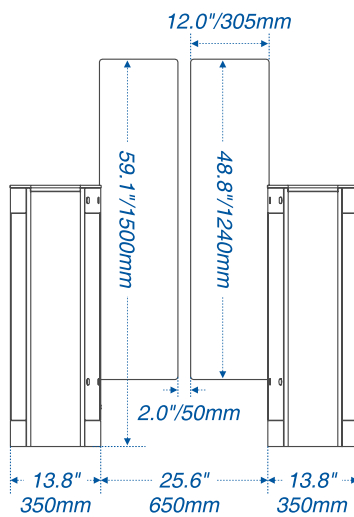

Side View

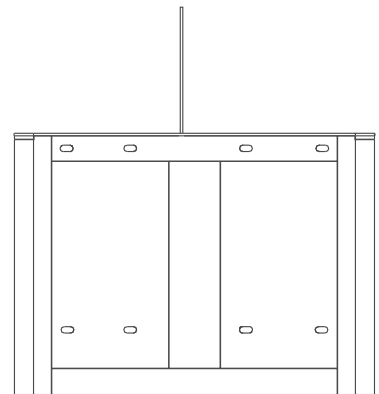

Top View

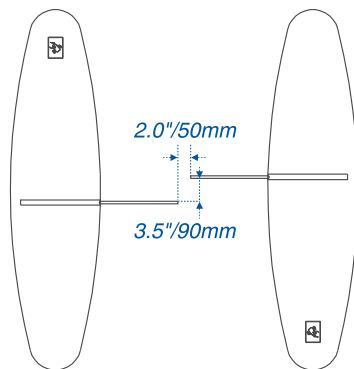

# Nergal-S4200

Unit: inch/mm

Bottom View

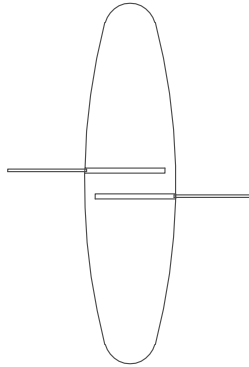

Side View

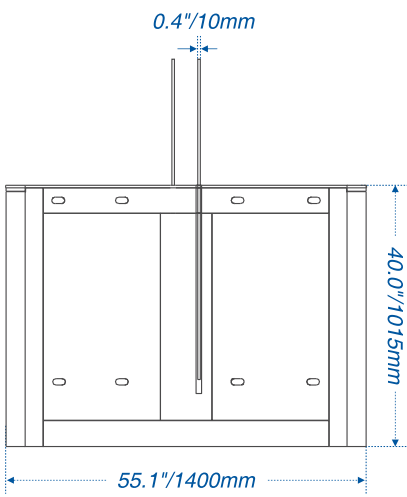

Front View

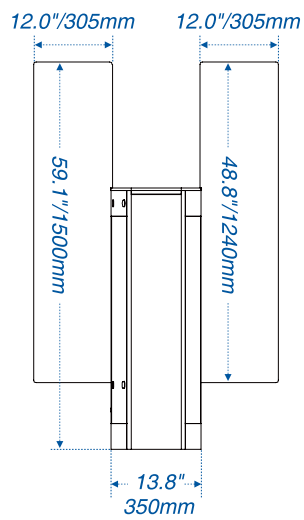

Side View

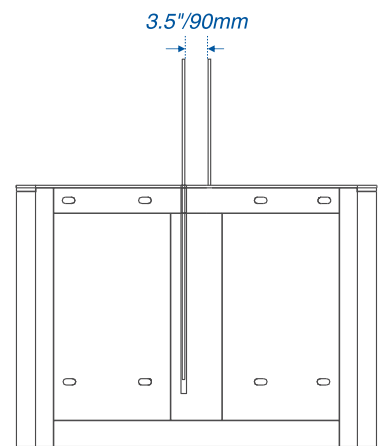

Top View

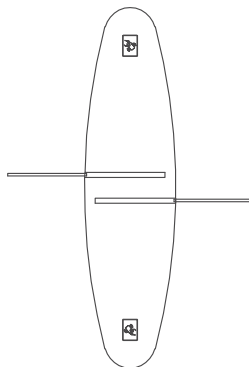

# 3 System Composition

The Nergal-S4000 and Nergal-S4200 can be combined to form a single, dual or multi-lane system, and users can choose the appropriate combination according to actual needs. It should be noted that Nergal-S4200 needs to be used in conjunction with Nergal-S4000.

## ● Single-lane

Unit: inch/mm

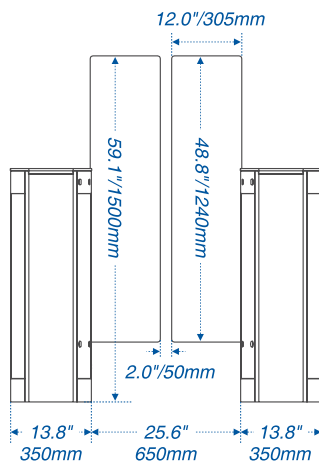

## ● Dual-lane

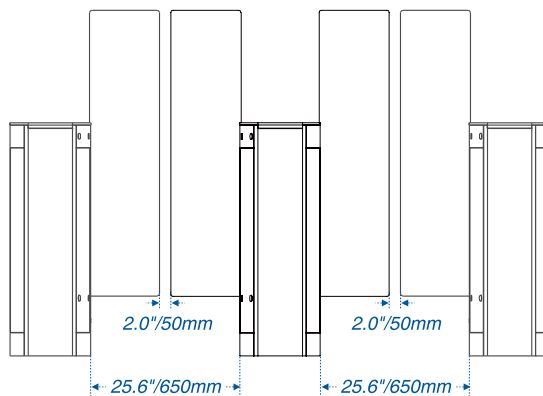

## ● Multi-lane

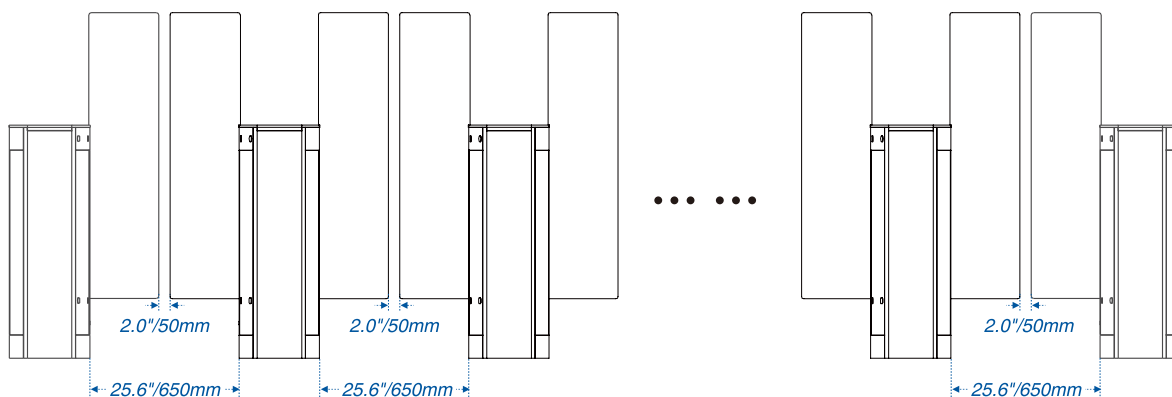

# 4 Components

The position of the main and sub devices will change in different combinations, and the wiring method will also be different. The following wiring is for reference only.

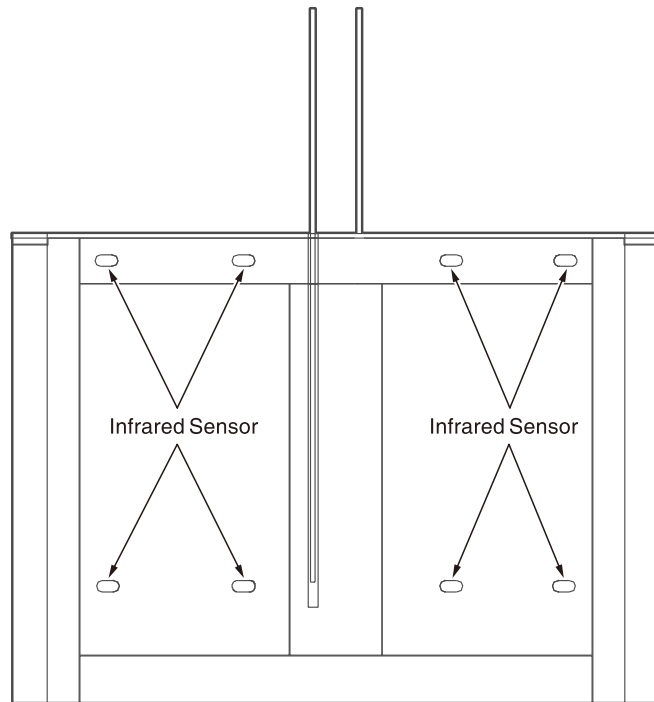

e.g. The position of the M/S devices in dual-lane mode.

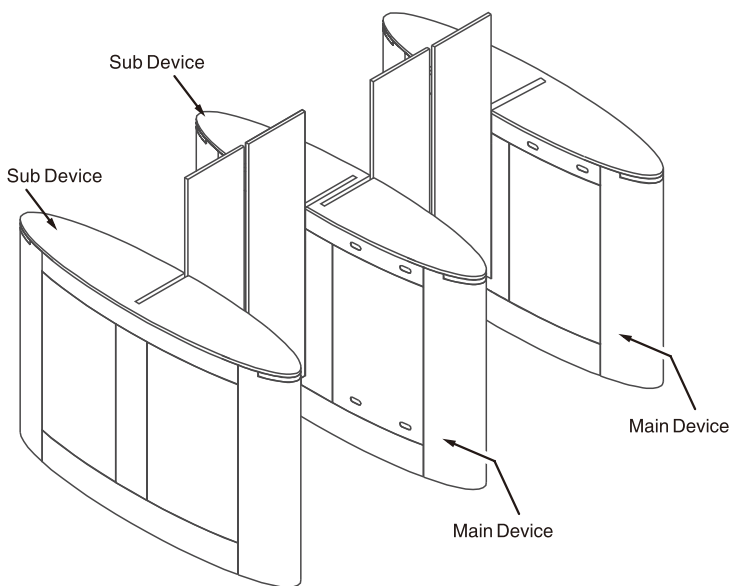

## ● Single-lane wiring

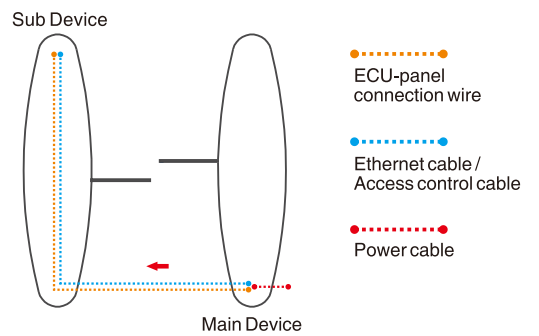

## ● Dual-lane wiring

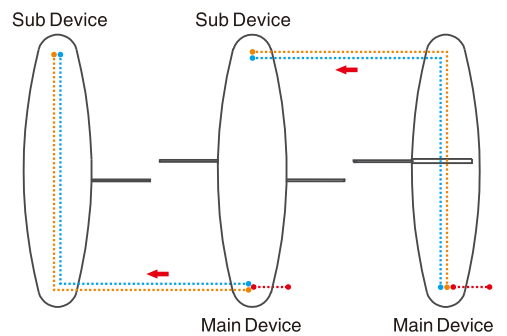

Remarks: The multi-lane wiring method is similar.

## 5 Installation Requirements

1. It is recommended that the turnstile must be installed on a horizontal solid platform with a height of **2.0" to 3.9" (50mm to 100mm)**.
2. It is recommended that the turnstile should not be used in the corrosive environment.
3. Make sure that the ground wire of the system is securely connected to avoid personal injuries or other accidents.
4. After installation, check if the connection has been done correctly at the connecting points of the ground wire, at the connector assemblies and wiring points of the circuits, as well as at each movable part of the turnstile. Any loose nuts, screws and other fasteners should be tightened in time to avoid any failures caused by long-time operations.

## 6 Installation Environment

1. Before installation begins, prepare installation tools, check the device and the accessories, and clear the installation base.
2. Make sure that the appliance is mounted on a concrete surface or other non-flammable surfaces.
3. The installation position of the turnstile depends on its size. A distance of **3.9" (100mm)** between the turnstile and the wall needs to be reserved for ease of opening the top lid of the turnstile to perform maintenance and adjustment. The reference figure is shown below:

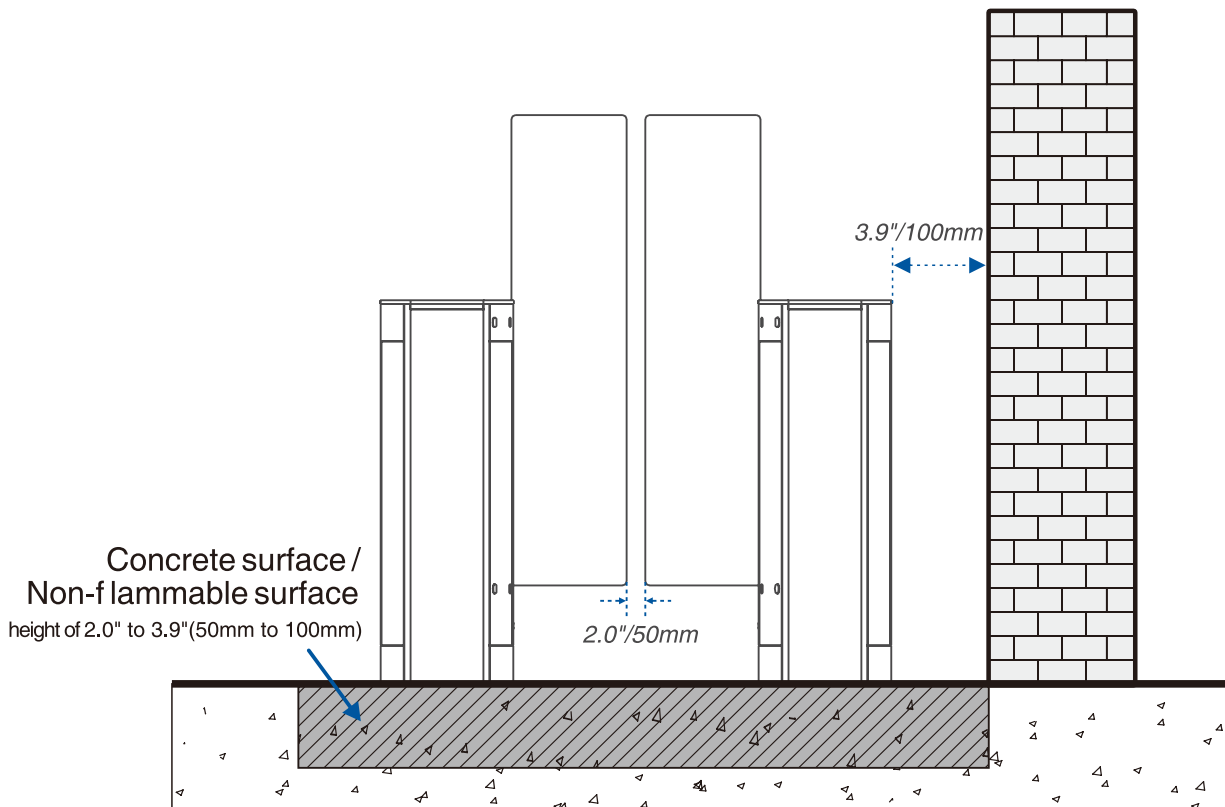



# 7 Installation Cabinet

## Step 1 Determine the mounting location

1. Use the key to open the cover of the cabinet and remove it.
2. Please refer to the user's manual and complete the **power-on self test** operation before installation.
3. Then place the cabinet according to the mounting distances shown in the diagram below. Take care to measure the distance between the bottom inside walls of the cabinets on the entrance side and exit side of the channel and make sure that the measurements are consistent.

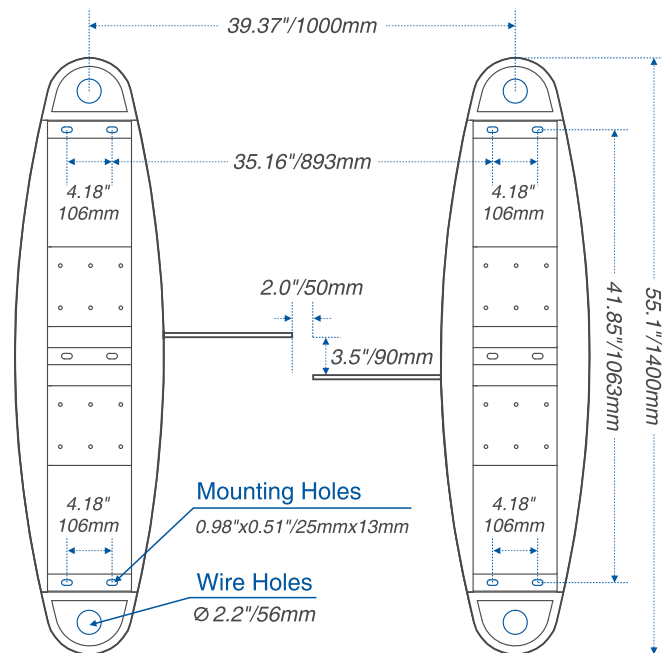

## Step 2 Marking Position

1. Draw the location of the cabinet with a marker and mark each location of the mounting holes. There will be a total of four mounting holes and two wire holes per cabinet.
2. Remove the cabinets when finished.

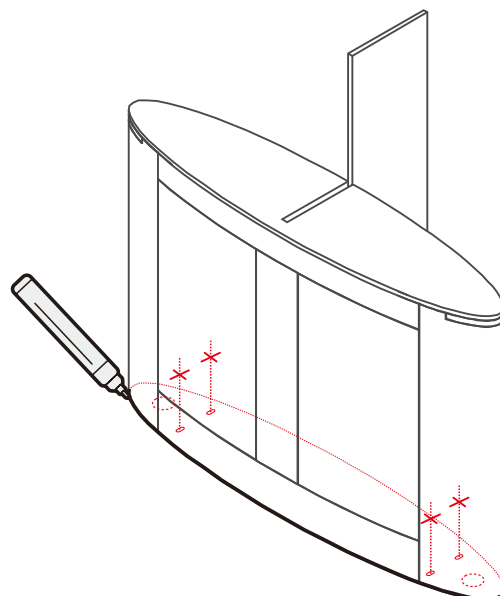

### Step 3 Drill holes and place bolts

1. Using a concrete drill bit, drill the mounting holes **2.4" (60mm)** in depth at the center of each marked location.
2. Then insert the bolts vertically into the mounting holes as shown at right.
3. Ensure expansion bolts are properly seated by applying three to five light taps with a rubber mallet until flush with the concrete surface. Verify anchor stability before proceeding.

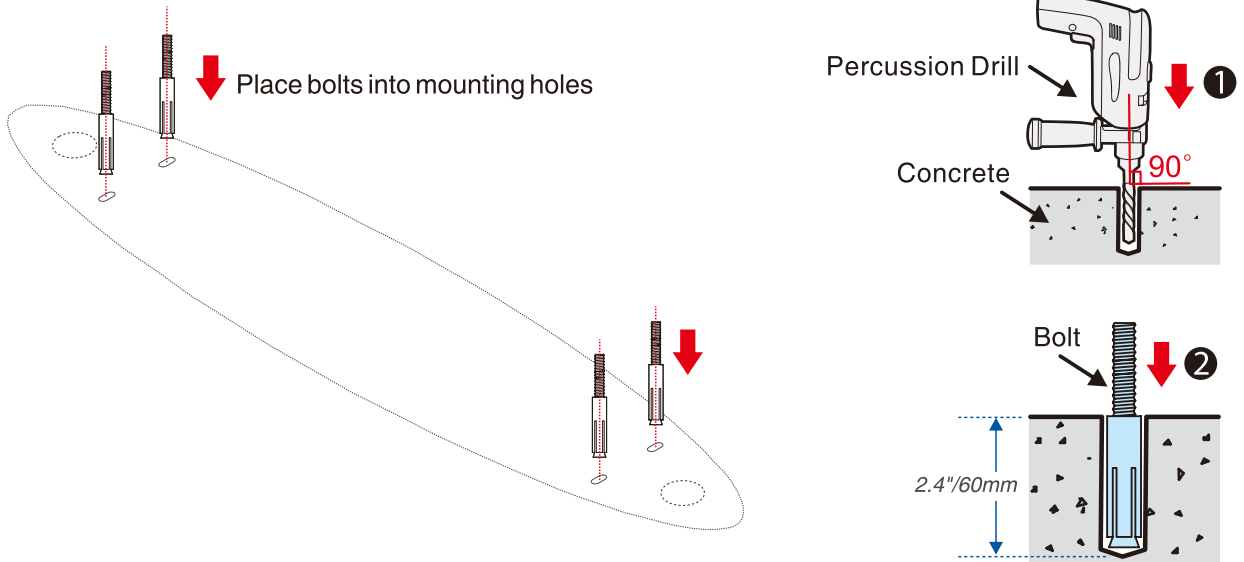

### Step 4 Wireway laying

1. Dig a recess of **2.0" (50mm)** depth between the wire holes on both sides of the channel with the dimensions shown below. Recesses can be dug at positions **1** and **2**.
2. Then lay two **0.8" to 1.0" (20 to 25mm)** diameter PVC pipes as shown below.
3. After threading the cable out of the PVC pipe, pour concrete to fix it in place.

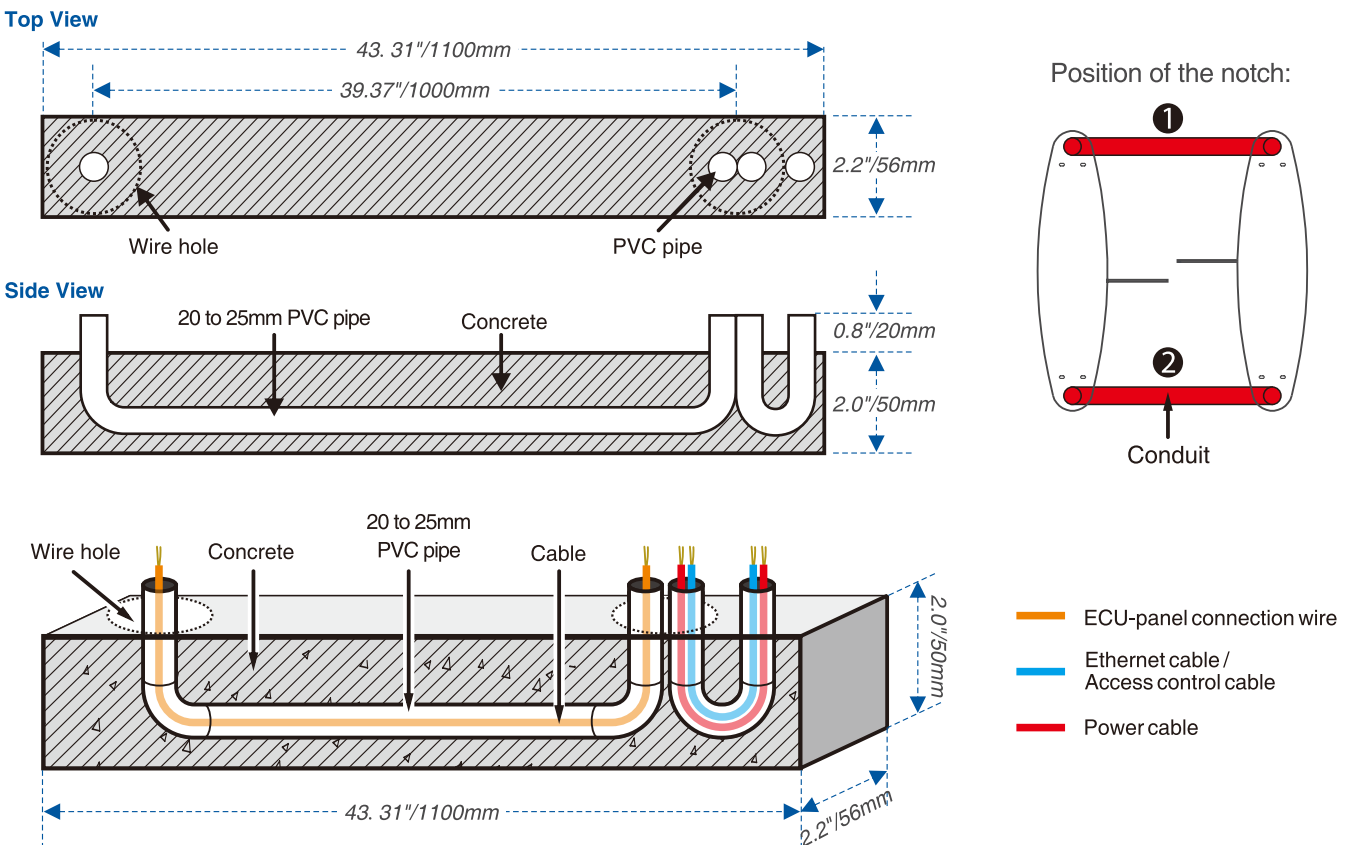

## Step 5 Fixed cabinet

1. After laying the PVC pipe, place the cabinet alignment bolts back into the mounting position.
2. Then insert the eight washers and nuts into the bolts one by one.
3. Tighten the nuts to hold the cabinet in place. Don't tighten it completely until after you're sure it won't move anymore. The finished result is shown below:

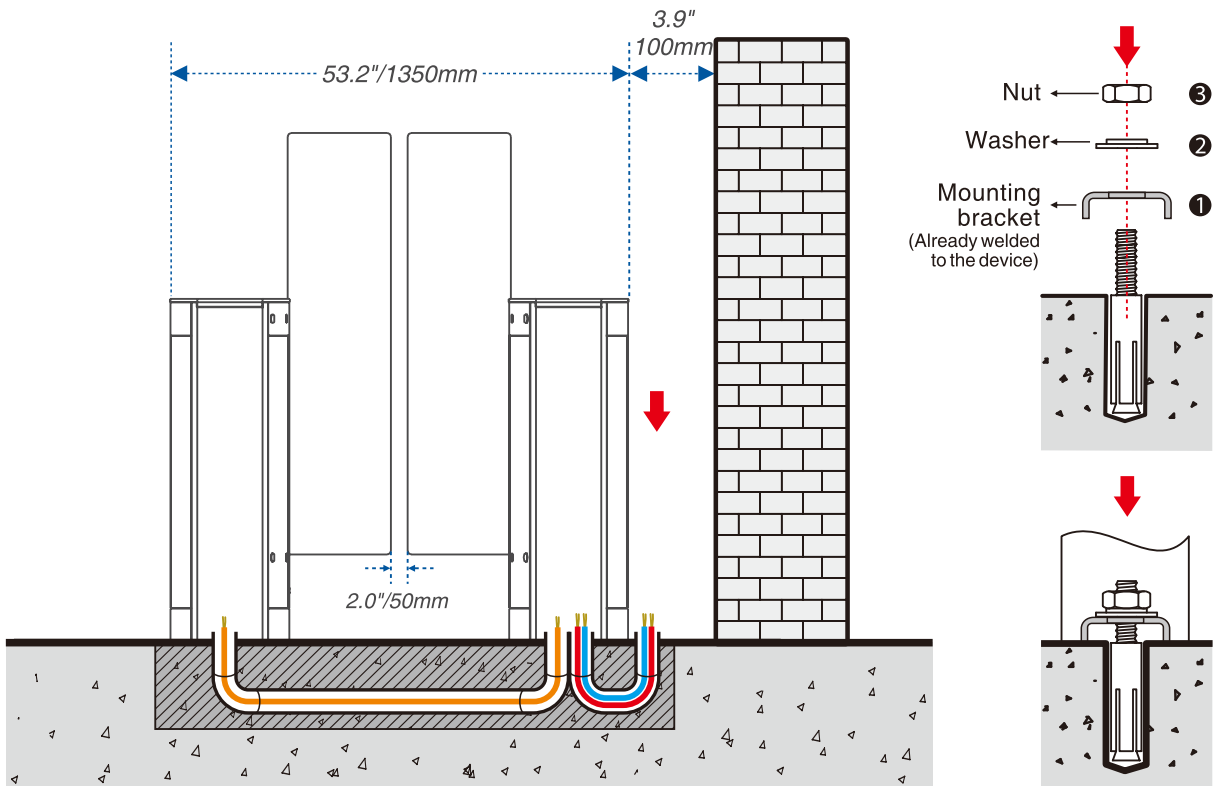

## Step 6 Marking the warning line

1. It is recommended that warning lines be marked on the ground and used to alert users.
2. A warning line can alert users to wait outside the line until the previous user completes the verification process and passes through the turnstile.

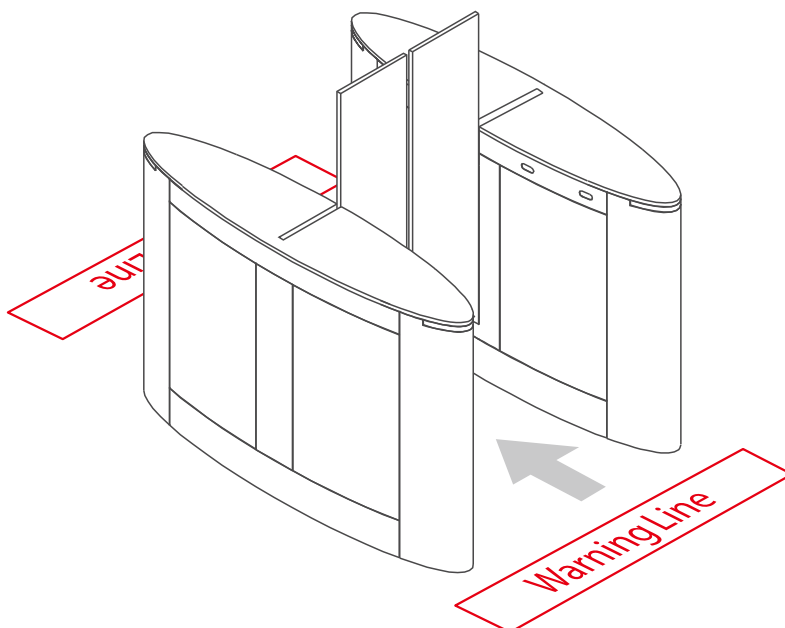

# 8 Wiring Diagram

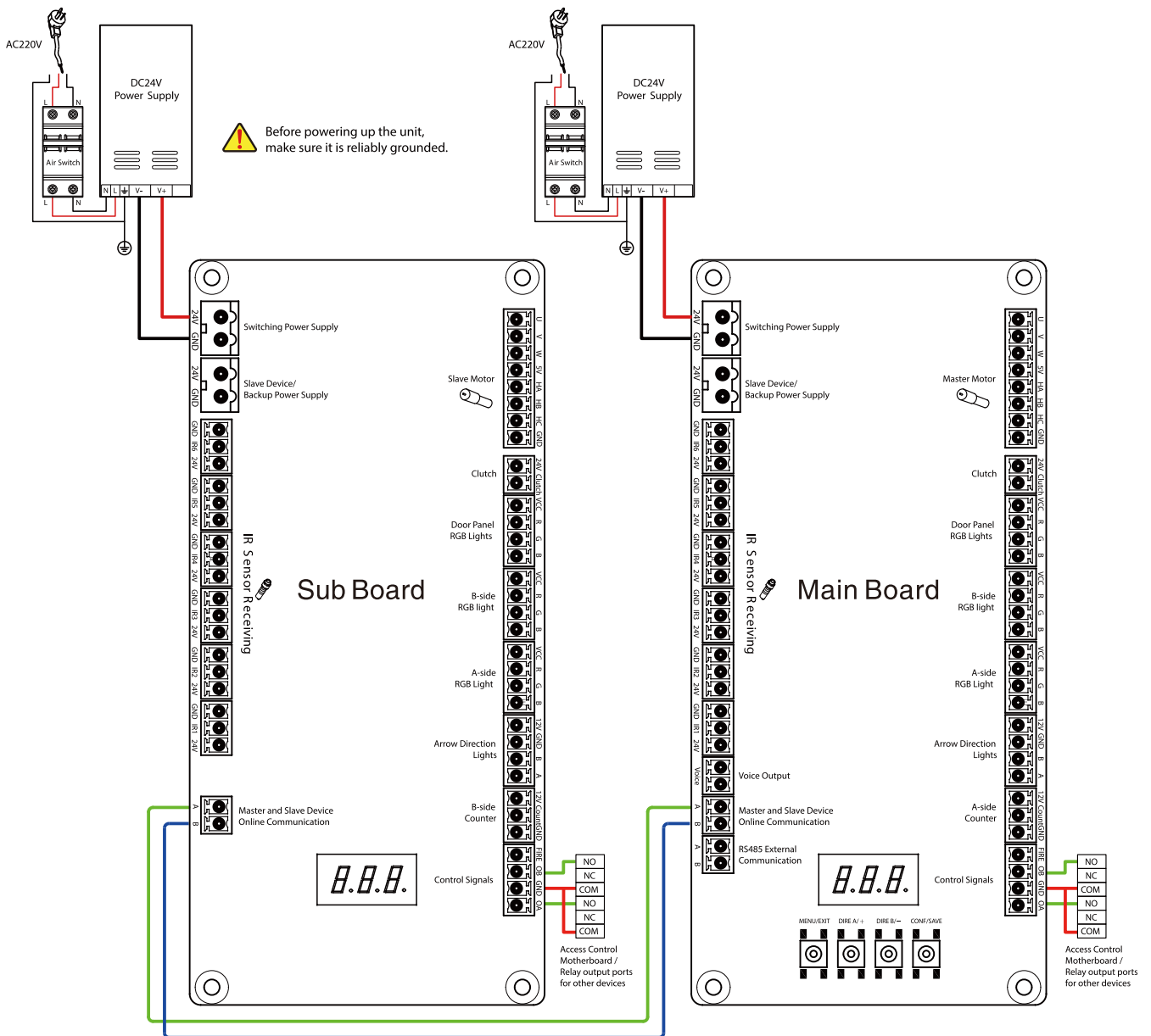

# ARMATURA

---

ARMATURA LLC    [www.armatura.us](http://www.armatura.us)    E-mail: [sales@armatura.us](mailto:sales@armatura.us)  
Copyright © 2025 ARMATURA LLC. All rights reserved.