

Avalon Series

Aesthetics Swing Barrier

Installation Guide

Version: 1.0

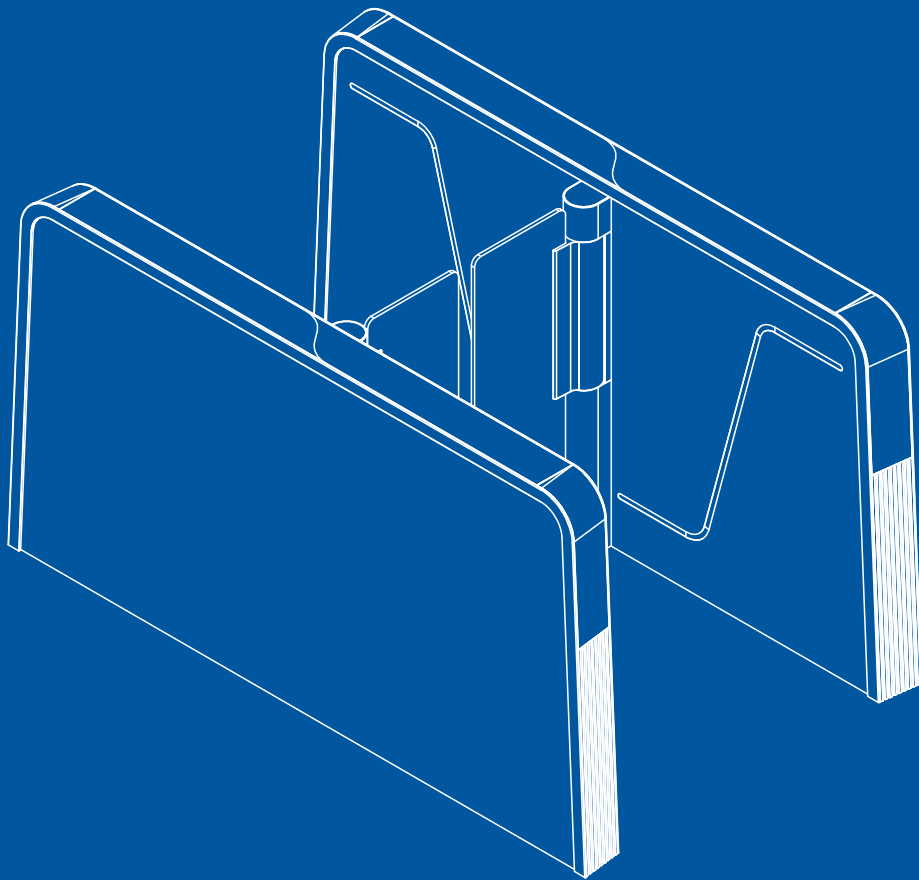

Revision History

Revision	Date	Author	Reviewer	Description
V1.0	02/12/2025	Julia.Huang		Original Document

1 Overview

Avalon-S1000

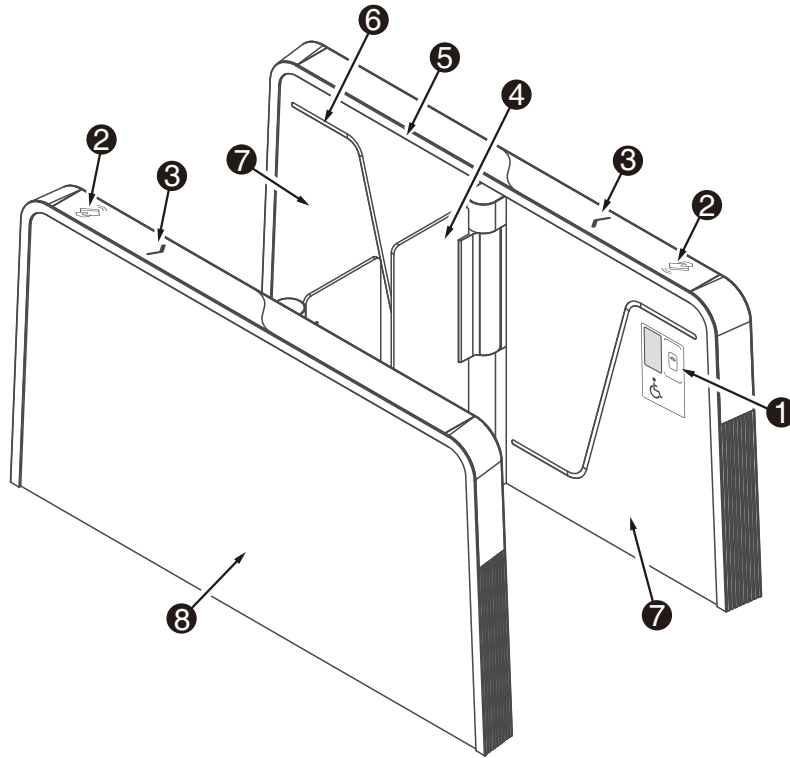

Avalon-S1200

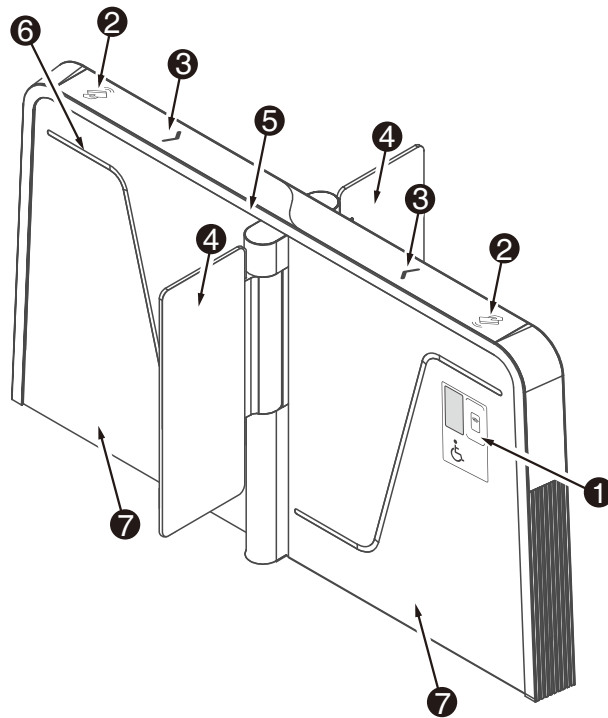

- ① Convenient Verification Area*
- ② Verification Area
- ③ Traffic Indicator
- ④ Barrier Material
- ⑤ Status Indicator
- ⑥ Infrared Sensor
- ⑦ Maintenance Door
- ⑧ Backboard

*This configuration provides an accessible design to accommodate individuals with mobility limitations.

2 Dimensions

Avalon-S1000

Unit: inch/mm

Top View

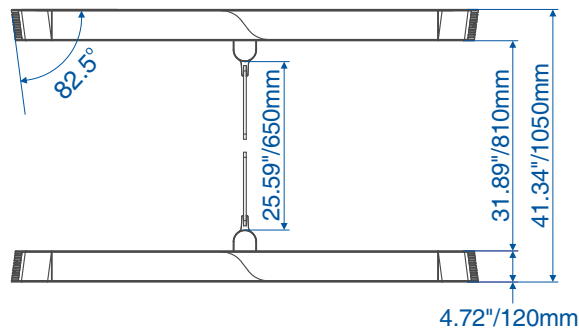

Side View

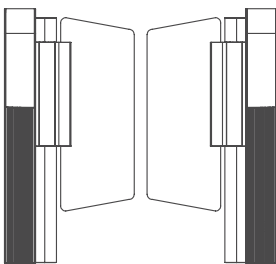

Front View

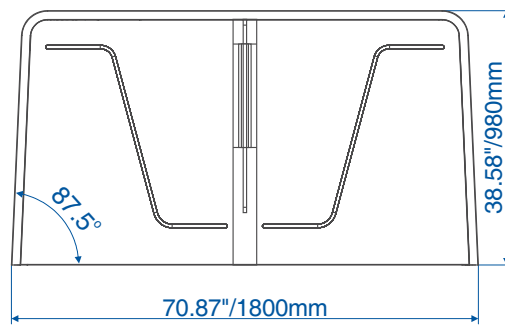

Side View

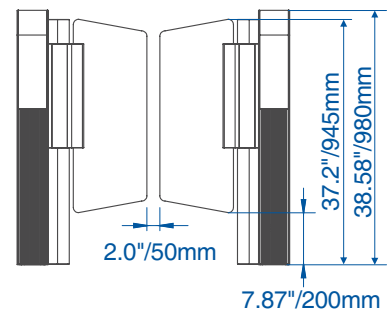

Bottom View

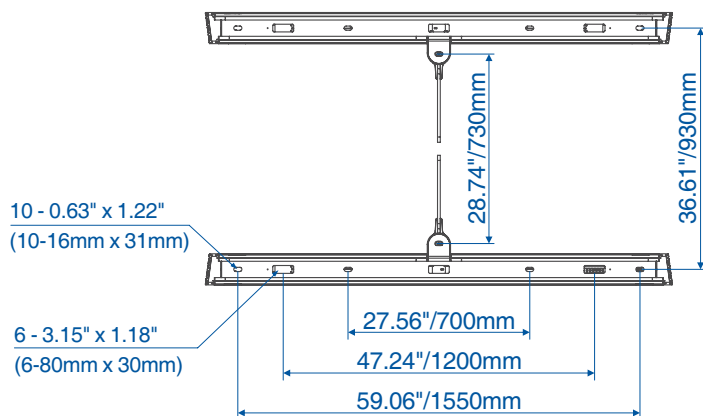

Avalon-S1200

Unit: inch/mm

Top View

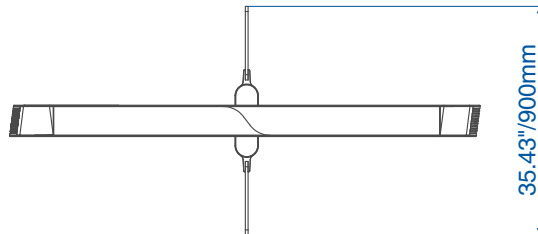

Side View

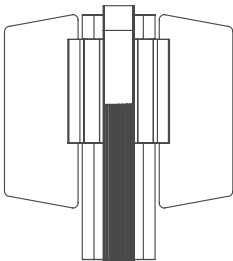

Front View

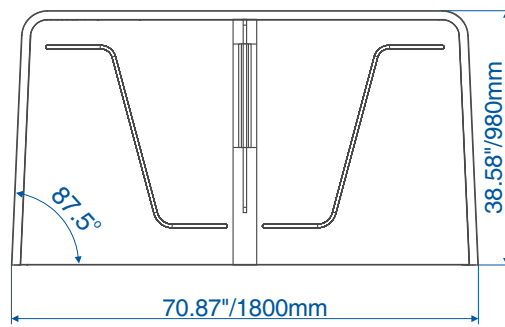

Side View

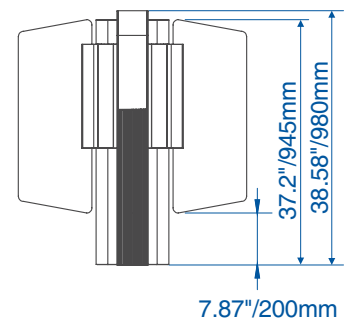

Bottom View

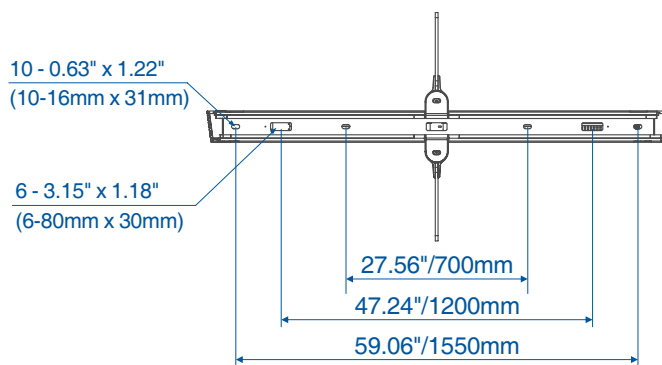

3 System Composition

The Avalon-S1000 and Avalon-S1200 can be combined to form a single, dual or multi-lane system, and users can choose the appropriate combination according to actual needs. It should be noted that Avalon-S1200 needs to be used in conjunction with Avalon-S1000.

● Single-lane

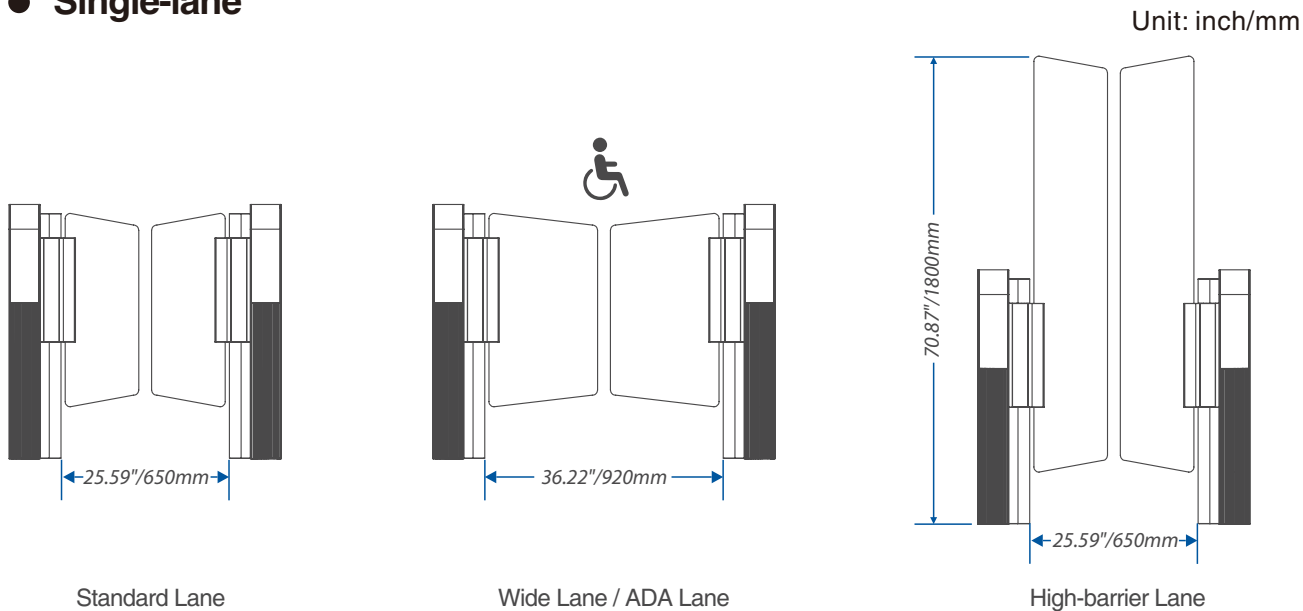

● Dual-lane

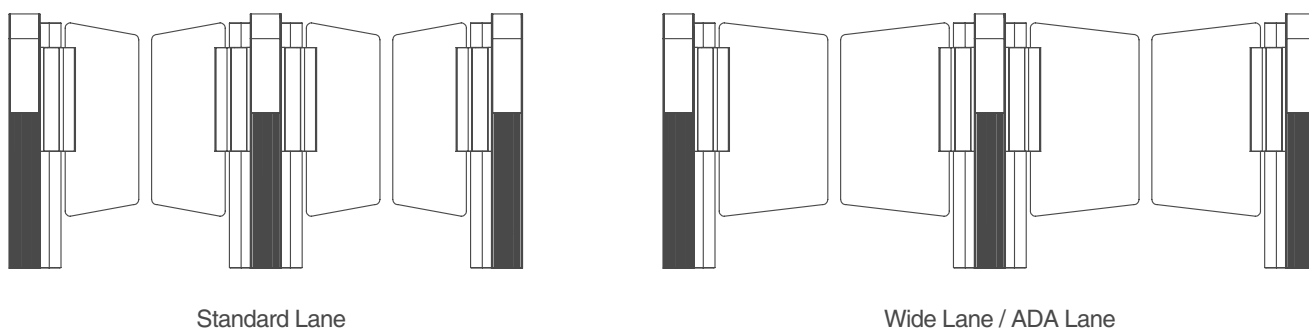

● Multi-lane

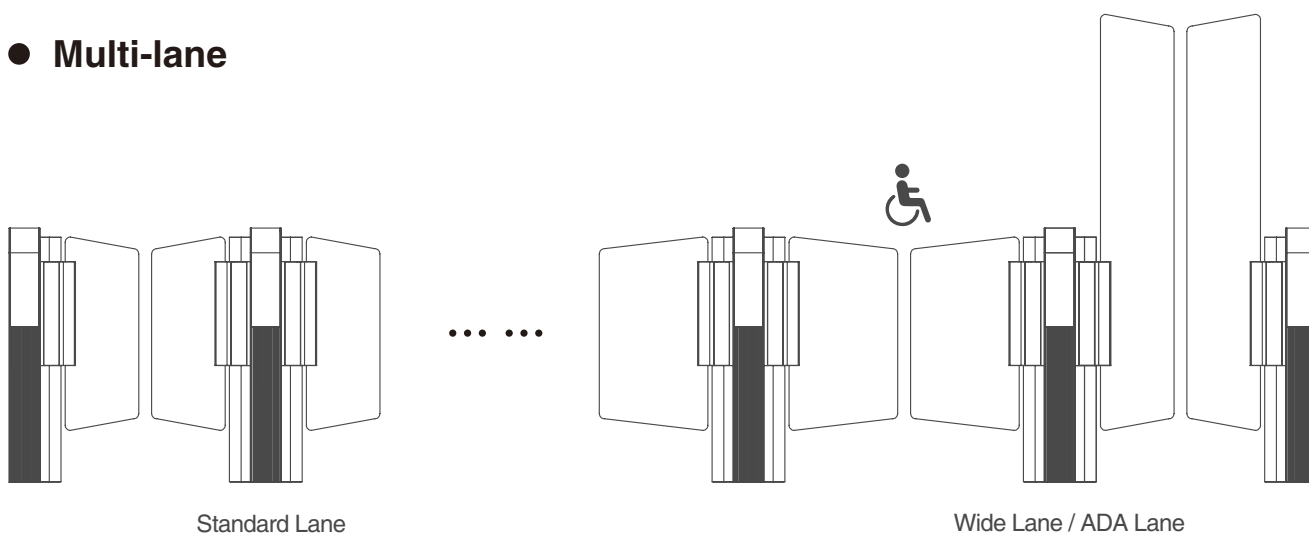

4 Wiring

● Single-lane wiring

Sub device

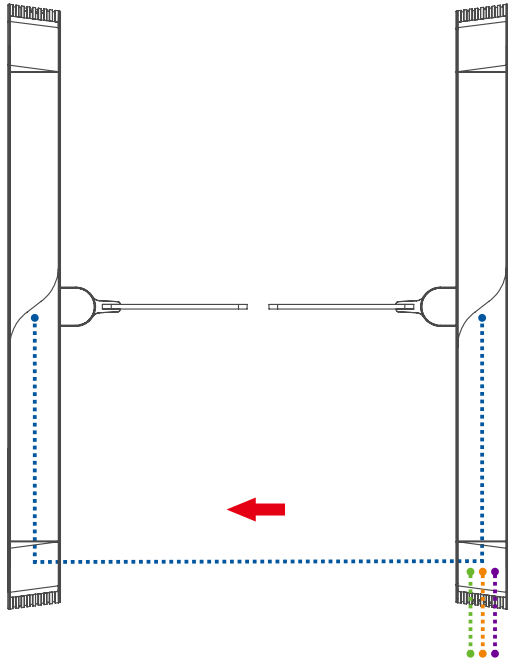

5-core connecting wire(M-S)

AC110/220V input

FACP (Fire alarm)

Access controller cable

Main device

● Dual-lane wiring

Sub device

Sub device

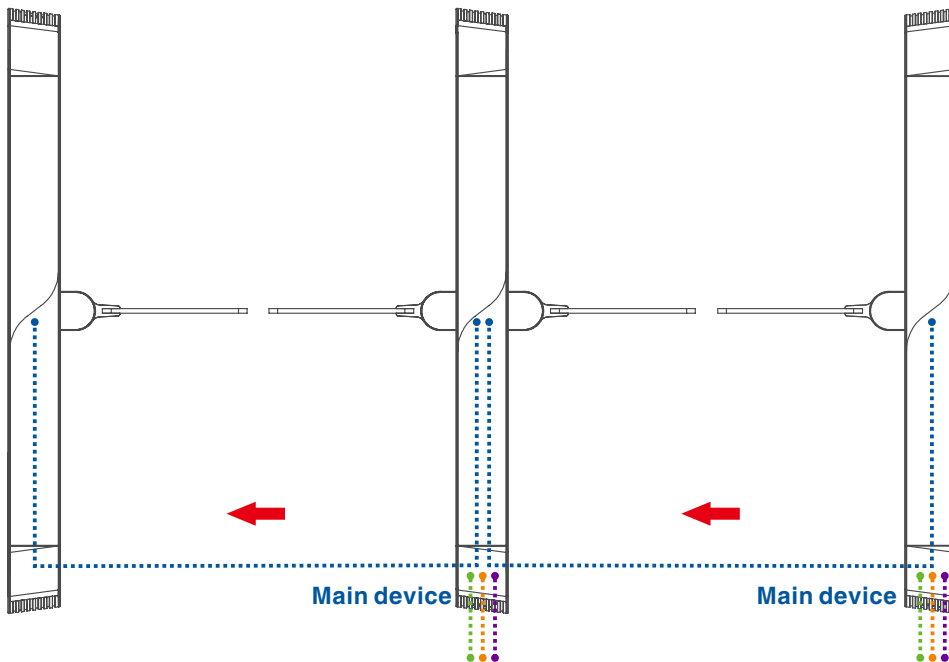

Main device

Main device

Remarks: The multi-lane wiring method is similar.

5 Installation Requirements

1. It is recommended that the turnstile must be installed on a horizontal solid platform with a height of **2.0" to 3.9" (50mm to 100mm)**.
2. It is recommended that the turnstile should not be used in the corrosive environment.
3. Make sure that the ground wire of the system is securely connected to avoid personal injuries or other accidents.
4. After installation, check if the connection has been done correctly at the connecting points of the ground wire, at the connector assemblies and wiring points of the circuits, as well as at each movable part of the turnstile. Any loose nuts, screws and other fasteners should be tightened in time to avoid any failures caused by long-time operations.

6 Installation Environment

1. Before installation begins, prepare installation tools, check the device and the accessories, and clear the installation base.
2. Make sure that the appliance is mounted on a concrete surface or other non-flammable surfaces.
3. The installation position of the turnstile depends on its size. A distance of **3.9" (100mm)** between the turnstile and the wall to allow for maintenance and adjustment. The reference figure is shown below:

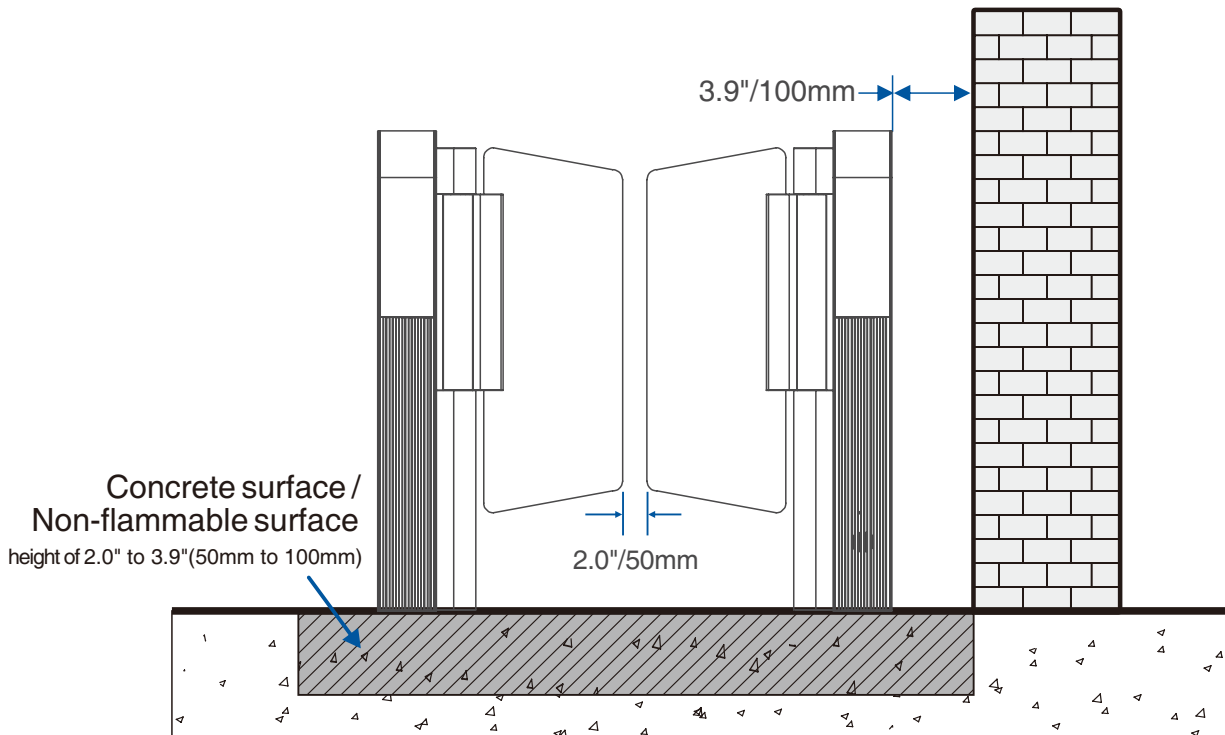

7 Installation Cabinet

Step 1 Determine and Mark the Mounting Positions

1. Please refer to the user's manual and complete the **power-on self test** operation before installation.
2. The first step is to determine the location for the cabinet installation. Once this has been done, the marking template should be placed according to the installation distances shown in the following figure. It is important to ensure that the distance between the inside walls of the cabinet on both sides of the channel inlet and outlet is measured consistently.
3. Then use a marker to mark the location of the **10** mounting holes and the outline of the mounting template.

● Standard Lane

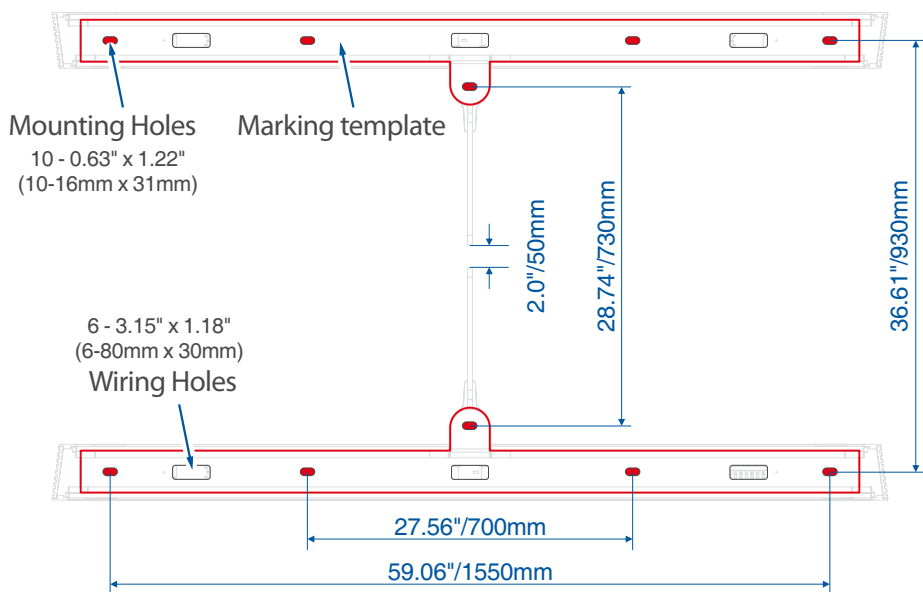

● Wide Lane / ADA Lane

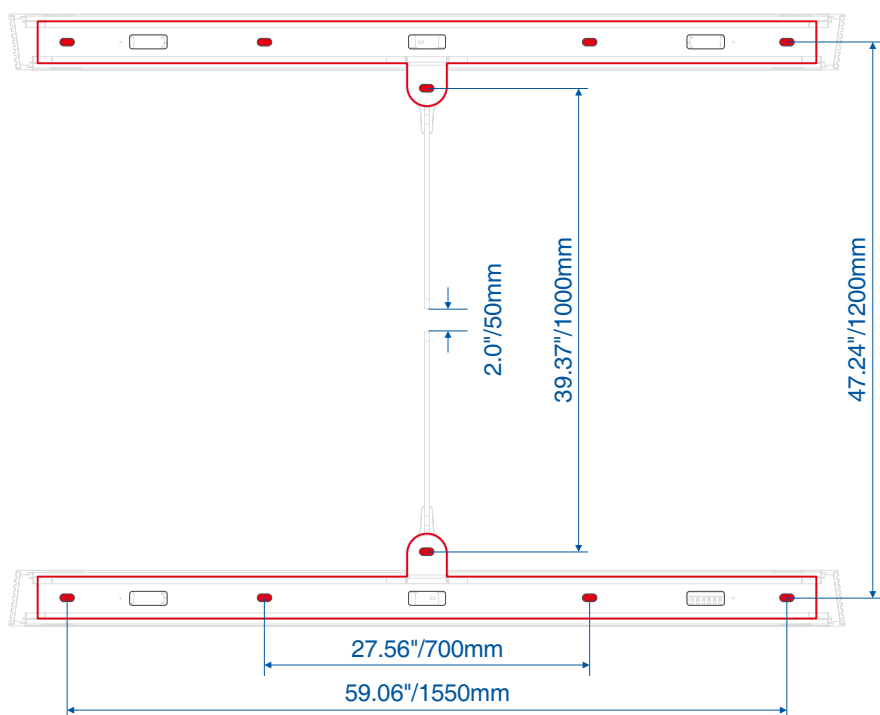

Step 2 Foundation and Pre-assembled Components

1. Dig a recess **2.0" (50mm)** deep with the dimensions shown below. For laying out pre-assembled components.
2. Place the pre-assembled components into the recess and pour concrete to fix it in place.

● Pre-assembled components:

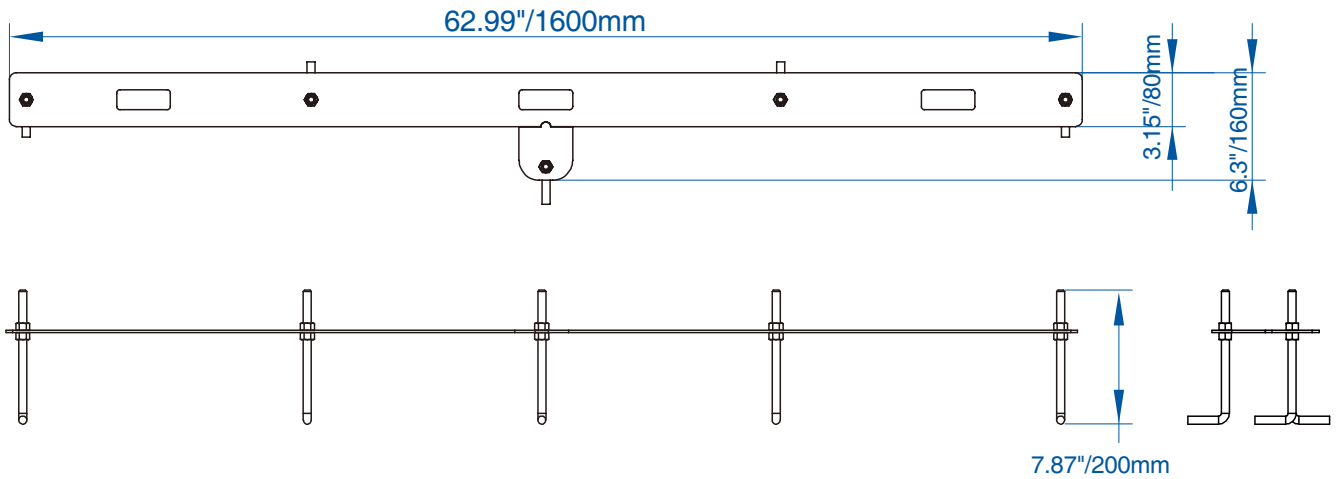

● Fixed the pre-assembled components:

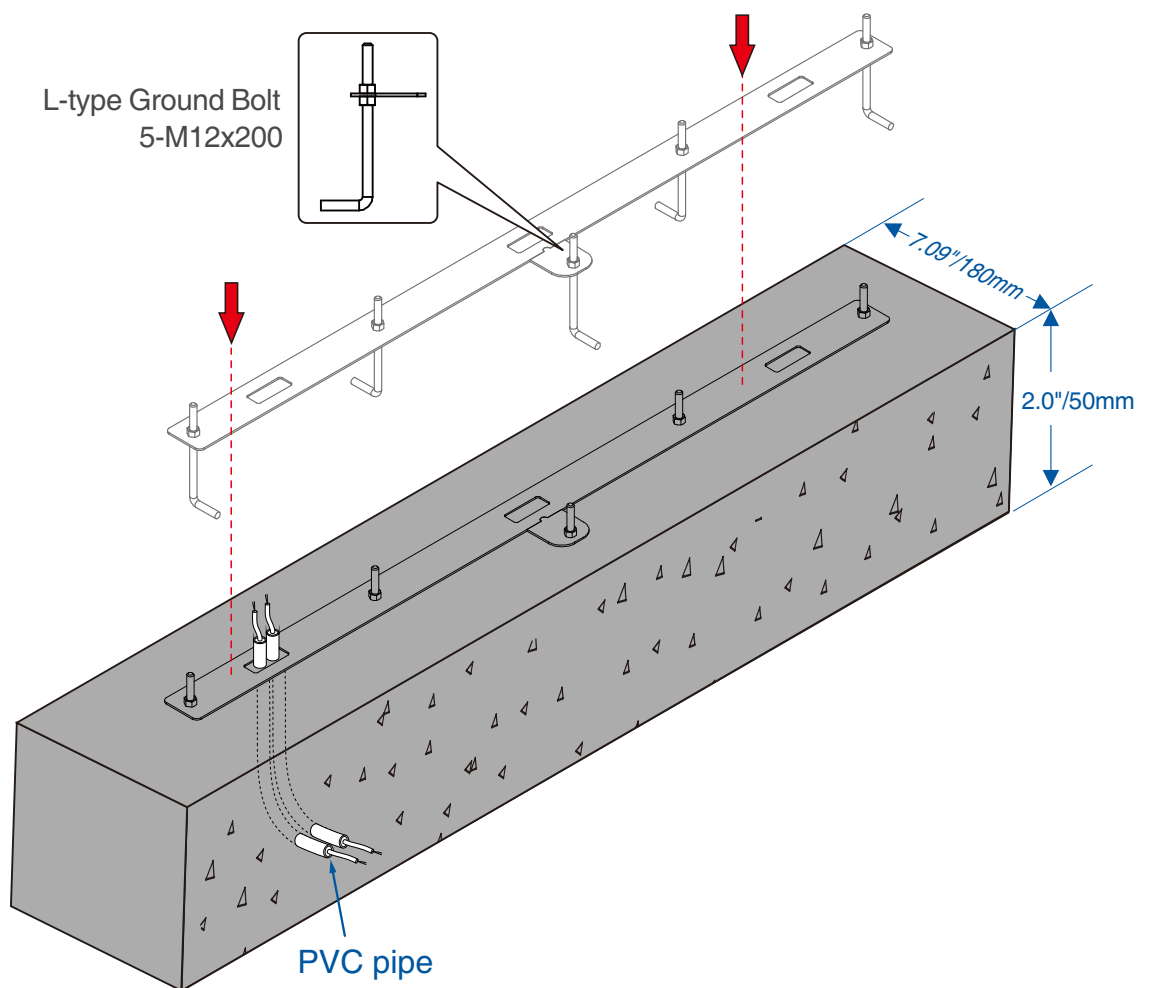

Step 3 Wireway Laying

1. Dig a recess of **2.0" (50mm)** depth between the wire holes on both sides of the channel with the dimensions shown below. Recesses can be dug at positions ① and ②.
2. Then lay two **0.8" to 1.0" (20 to 25mm)** diameter PVC pipes as shown below.
3. After threading the cable out of the PVC pipe, pour concrete to fix it in place.

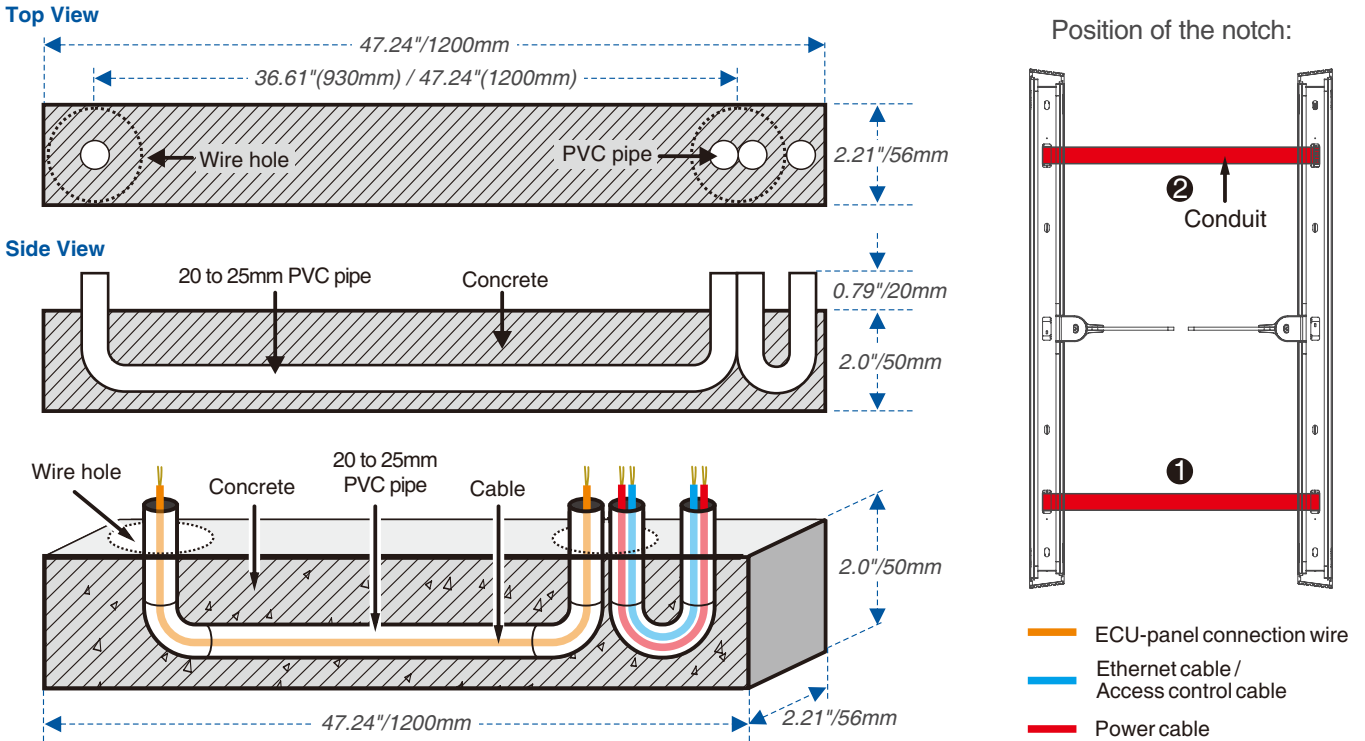

Step 4 Fixed Cabinet

1. After laying the PVC pipe, place the cabinet alignment bolts back into the mounting position.
2. Then insert the nuts into the L-type ground bolts one by one.
3. Tighten the nuts to hold the cabinet in place. Don't tighten it completely until after you're sure it won't move anymore. The finished result is shown below:

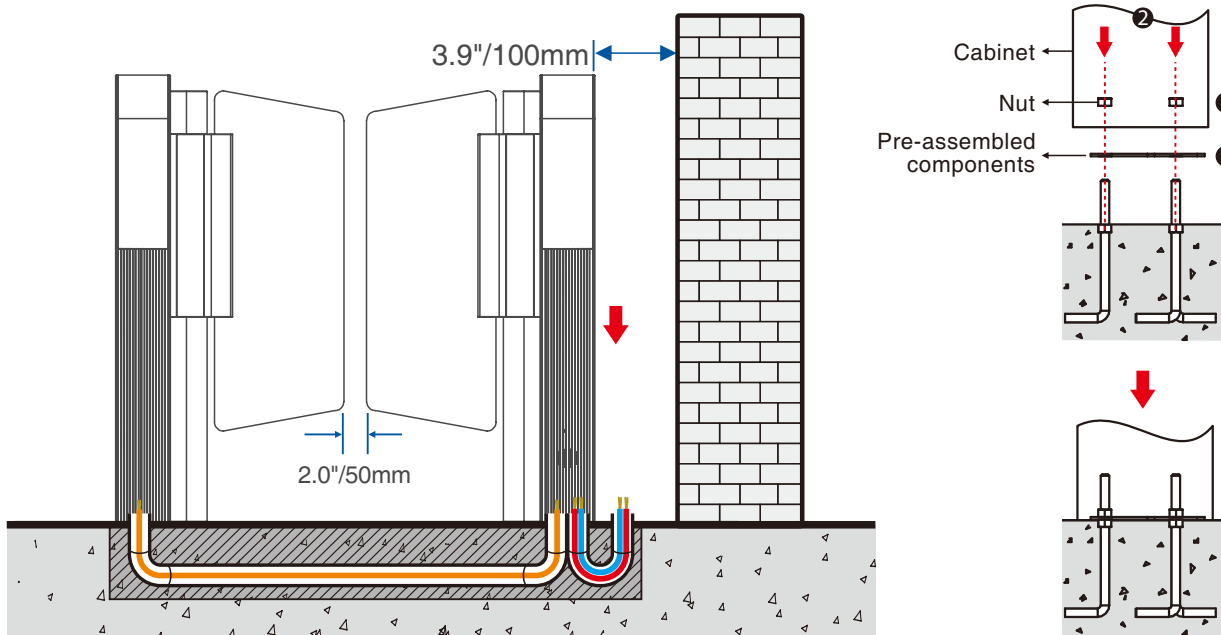

8 Detailed Installation Instructions

Step 1 Removal of Gantry Frames

1. Remove gantry frame

Working in pairs or multiples, lift the gantry frame from each end and remove the gantry frame once it is raised. Take care to maintain balance at both ends.

Note: After the frame is raised, unplug electrical connections such as indicator lights, speakers, etc. before removing the gantry frame.

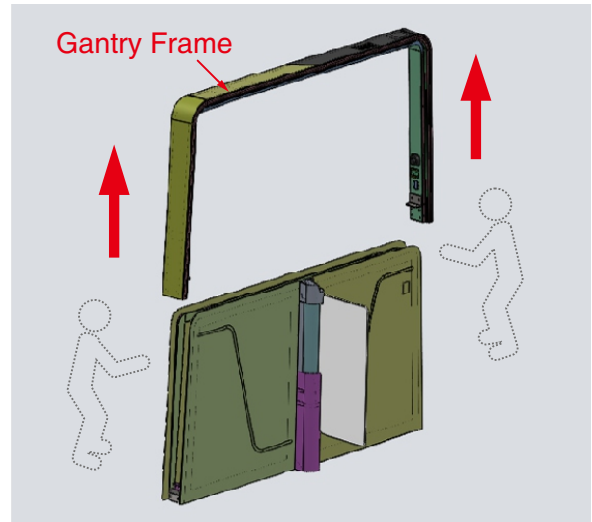
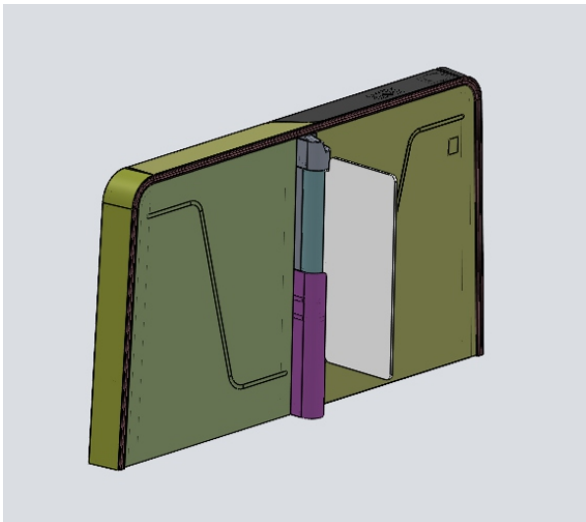

2. Disassembly of maintenance door assembly

Remove the maintenance door fixing screws from the top and then remove it with a glass suction cup.

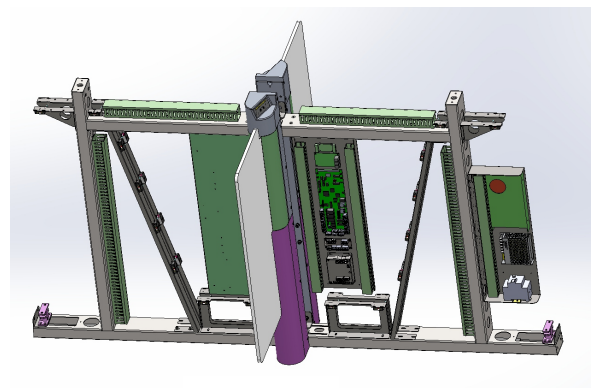
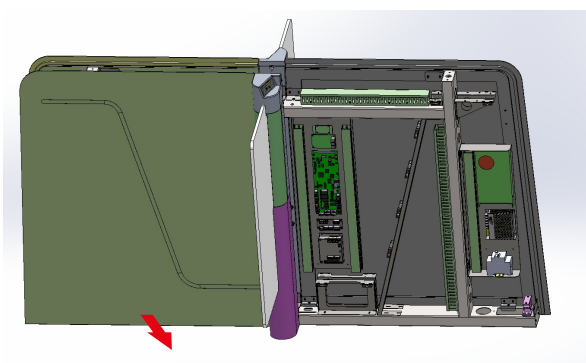
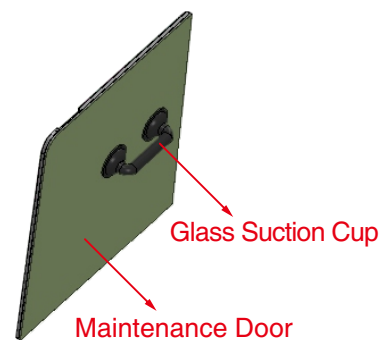
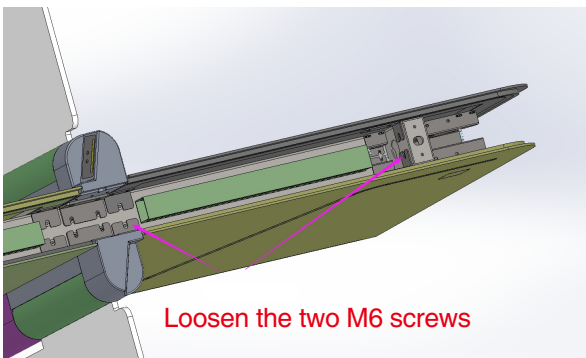

3. Removing the movement lower cover

Loosen the screws of the lower movement cover and remove the cover.

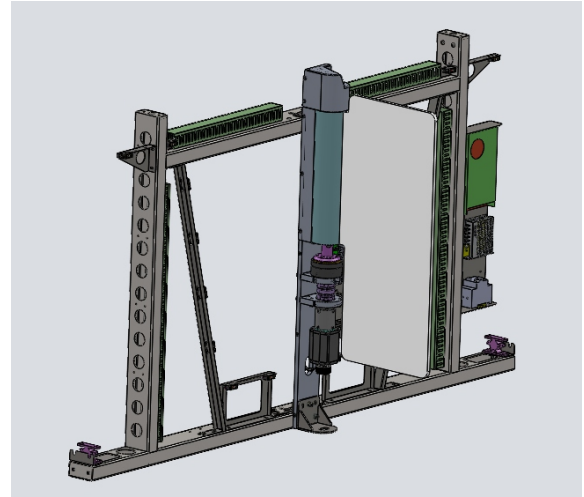
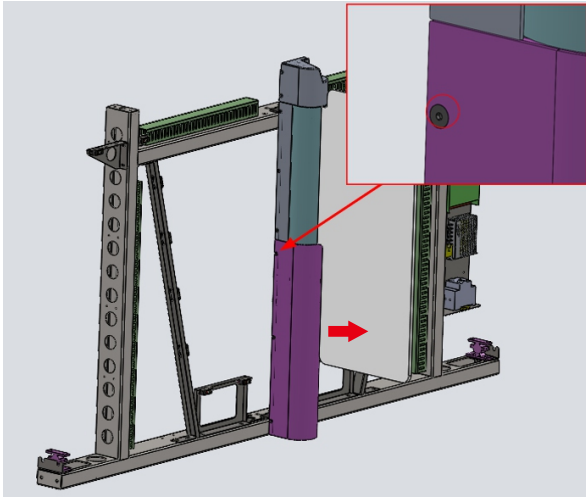

Step 2 Mounting Fixing

1. Place the chassis on the pre-mounted L-type ground screws in accordance with the fixing holes on the bottom of the chassis, and lay the communication cables and 220V power cables at the same time.

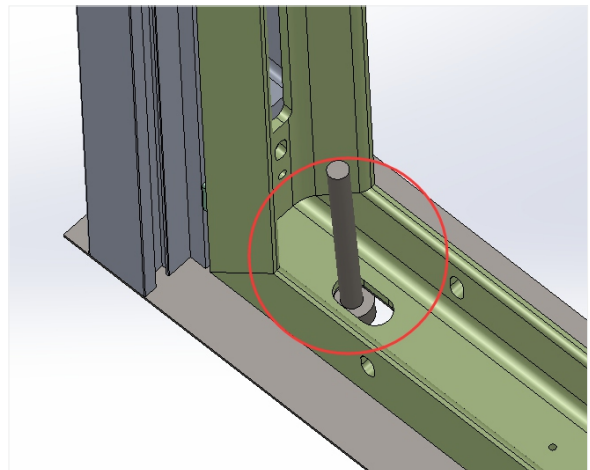
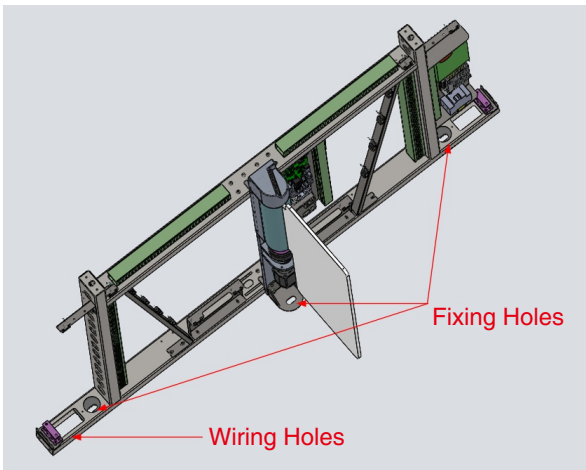

Step 3 Put the Gantry Frames Back On

1. After tightening the chassis, install the lower movement cover and then the maintenance door assembly.

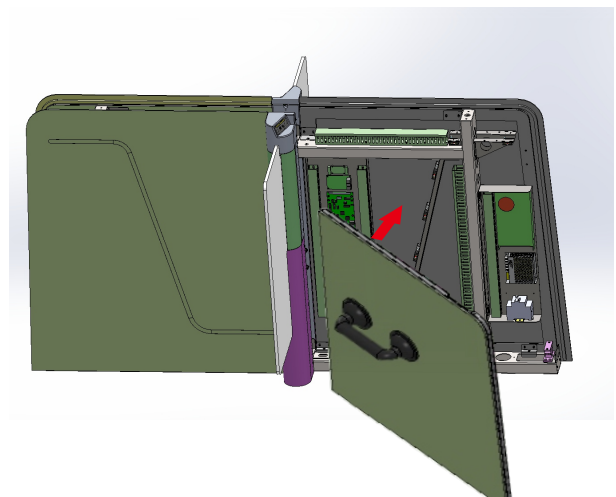
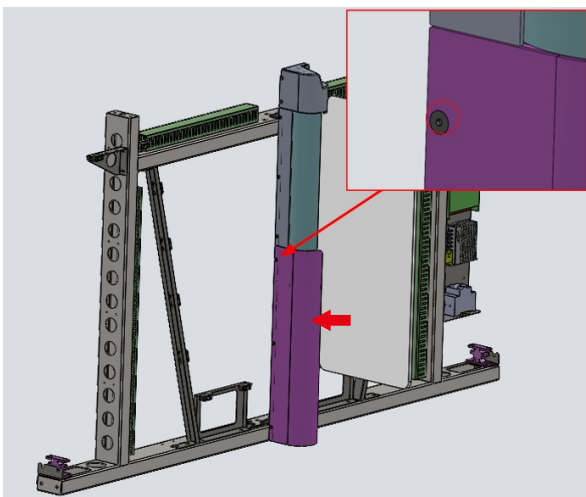

2. Installation of gantry frames

Align the locating pins and concealed fasteners on the gantry frame, and with two people working together, insert the frame flush into the gate box body.

Note: Connect the indicator lights, speakers and other electrical appliances.

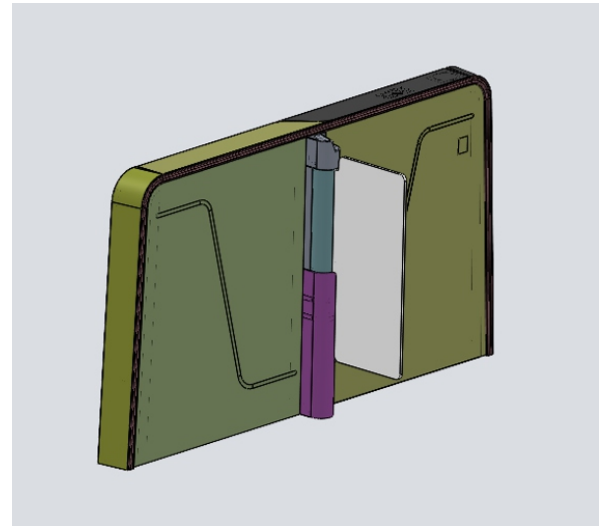
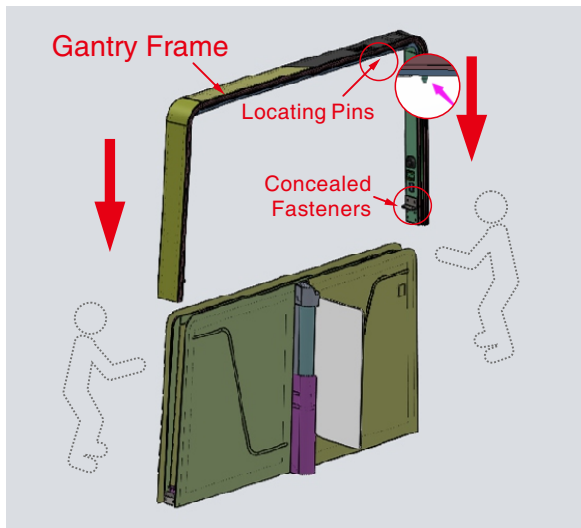

Step 4 Marking the Warning Line

1. It is recommended that warning lines be marked on the ground and used to alert users.
2. A warning line can alert users to wait outside the line until the previous user completes the verification process and passes through the turnstile.

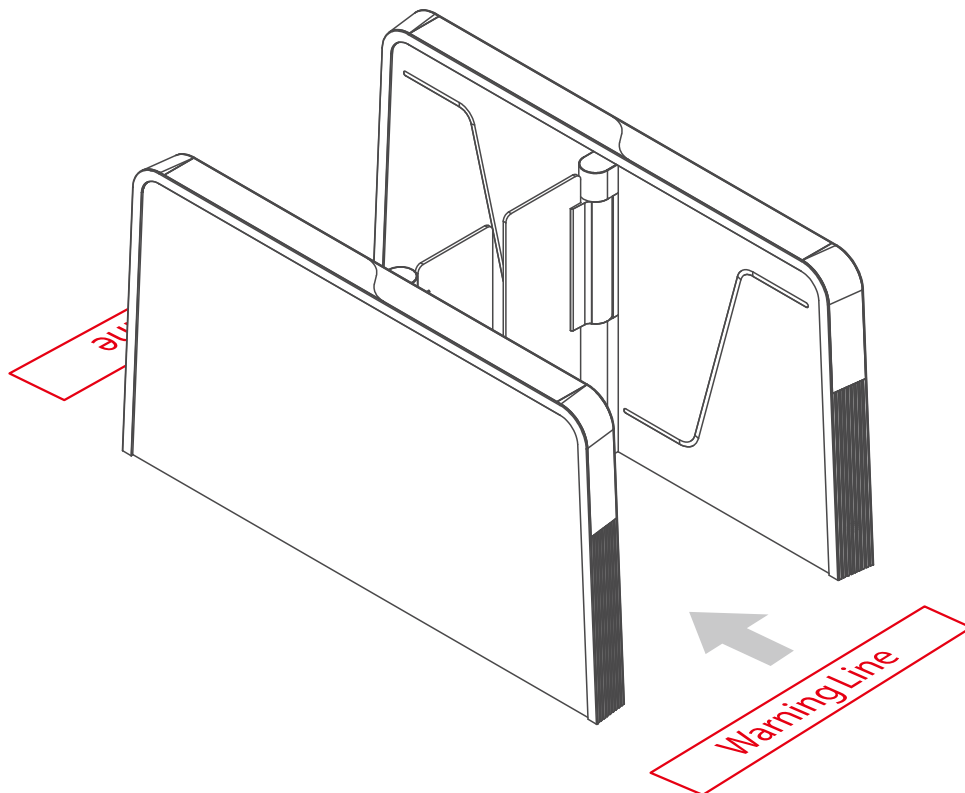

9 Wiring Diagram

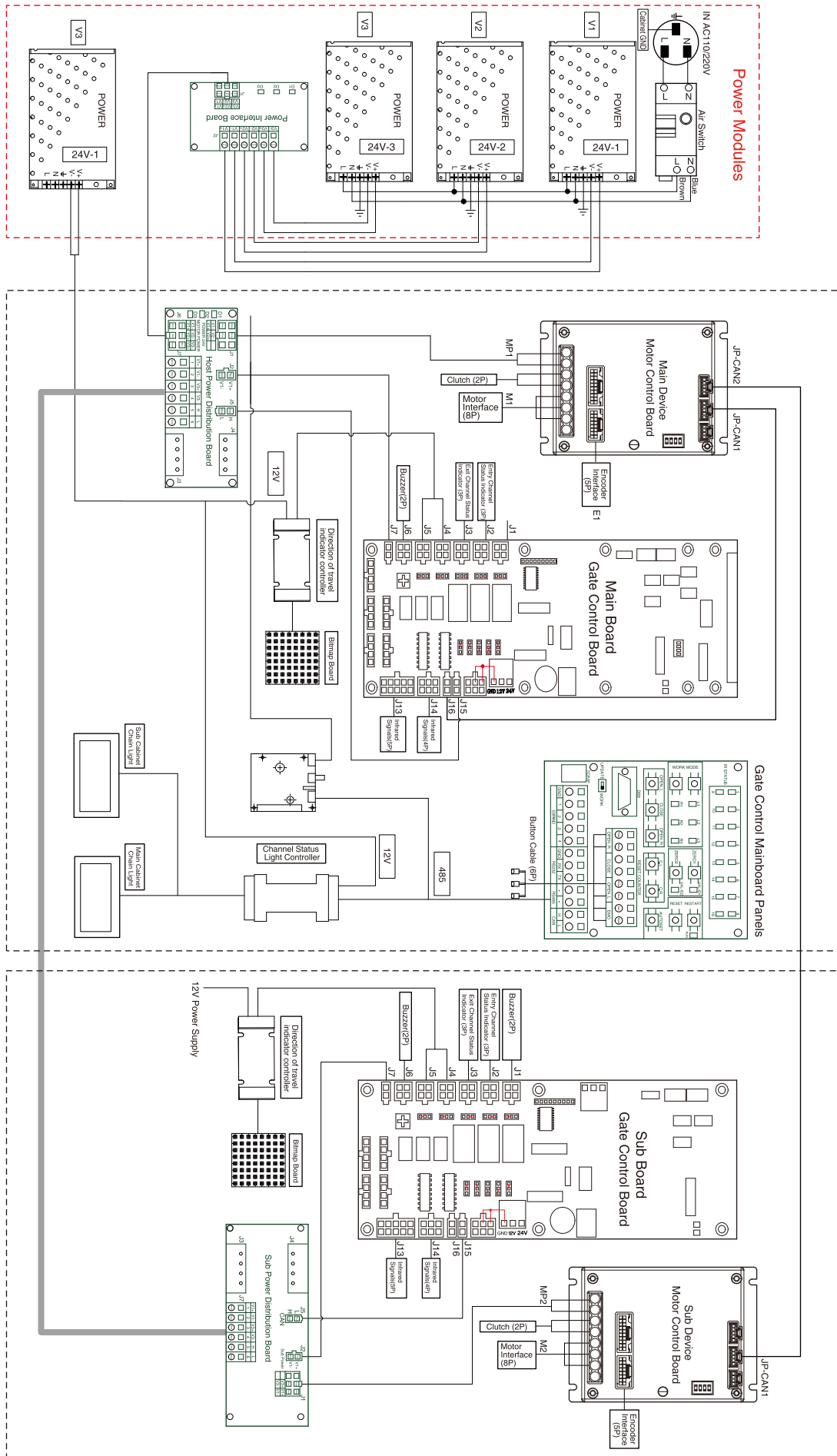

Main Cabinet Wiring Diagrams

Sub Cabinet Wiring Diagrams

ARMATURA

ARMATURA LLC www.armatura.us E-mail: sales@armatura.us
Copyright © 2025 ARMATURA LLC. All rights reserved.